

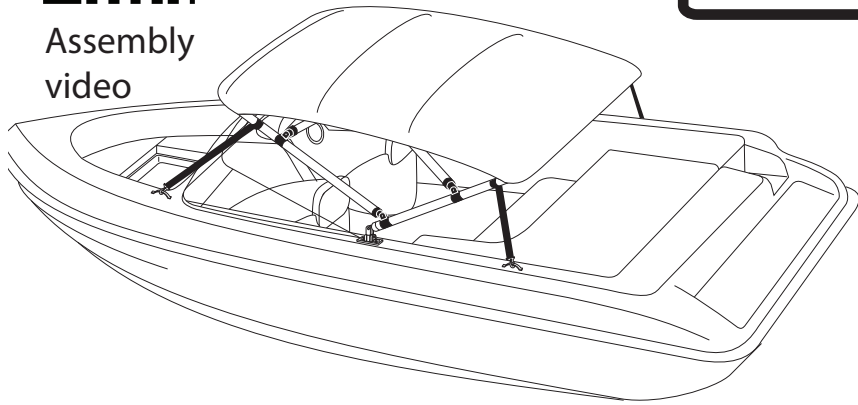

Assembly video



4-Bow Aluminum Bimini Assembly Instructions

Westland®

4-Bow Aluminum Bimini Assembly Instructions

Important!

Each bow part is labeled with the bow number -1, -2, etc. Organize bow pieces by grouping together all -1s, all -2s, etc.

If your bimini is missing any of these parts, please contact the retailer or dealer from whom you purchased the bimini before proceeding with the installation.

3

Bow Pieces Package Contents

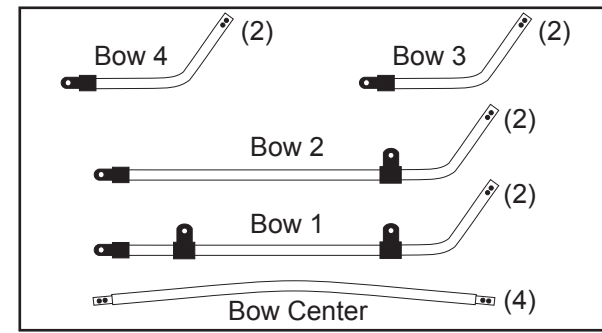

Hardware Kit

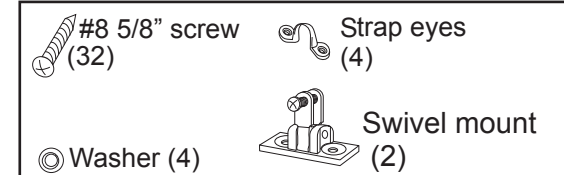

Strap Kit



Tools Required

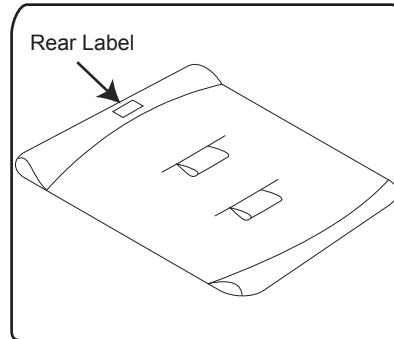
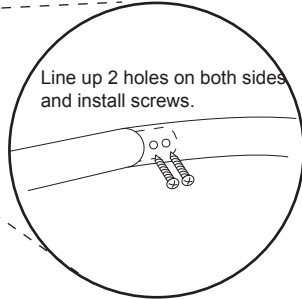
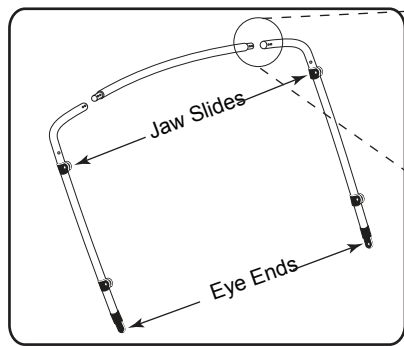
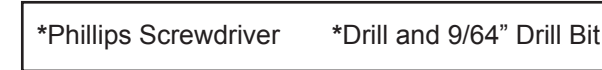

1 Assemble pieces of Bow 1 by attaching both Bow 1 sides to the Bow 1 center.

2 ... and inserting 5/8" screws as shown. Repeat steps 1 and 2 for other bows.

3 Lay bimini fabric face down on a flat clean surface (label on rear sleeve will be facing up)

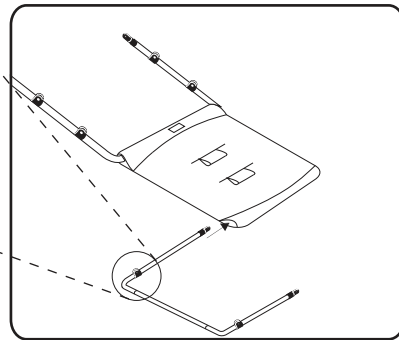
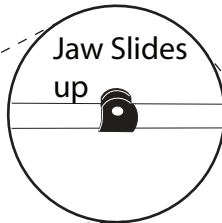
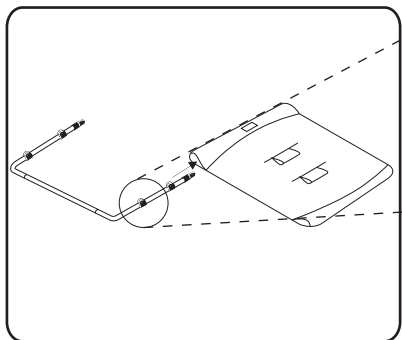

4 Position Bow 1 as shown with jaw slides facing up. Thread Bow 1 thru rear sleeve.

5 Position Bow 2 as shown with holes facing up. Thread Bow 2 through front sleeve of fabric.

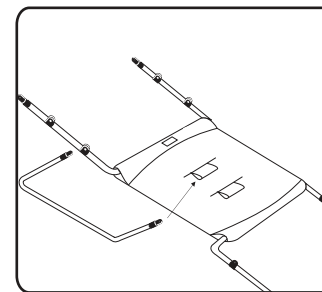

6 With other bows extended away from top, thread Bow 3 through middle sleeve.

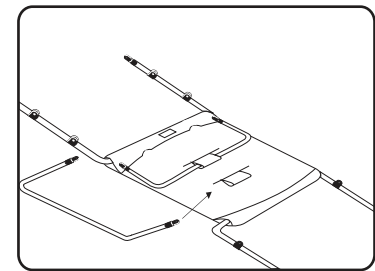

7 Thread Bow 4 through front center sleeve.

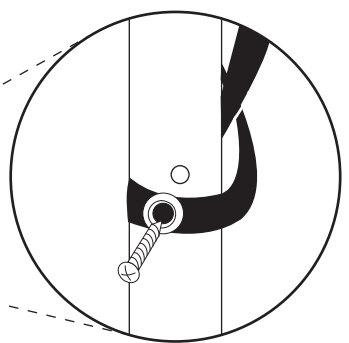
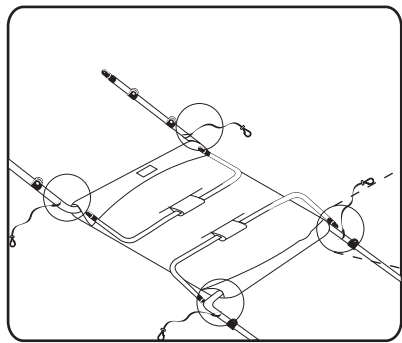

8 Pass looped end of each hold down strap over end of bow.

9 Line up hole in each strap with the hole in the bow. Insert #8x5/8" screw through washer and strap, and secure into bow. Strap should extend away from the top. Repeat for remaining bow straps.

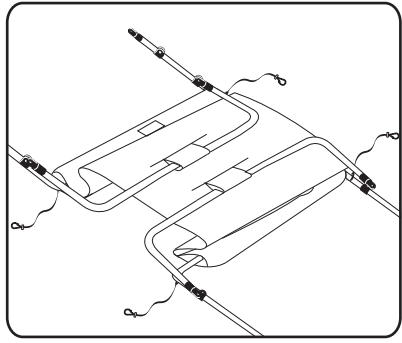

10 Remove screws from Bow 1 jaw slide nearest to Bow 3. Thread screw through jaw slide and Bow 3 eye end and secure to connect pieces. Eye ends will rotate to line up. Repeat steps above with Bow 2 and Bow 4.

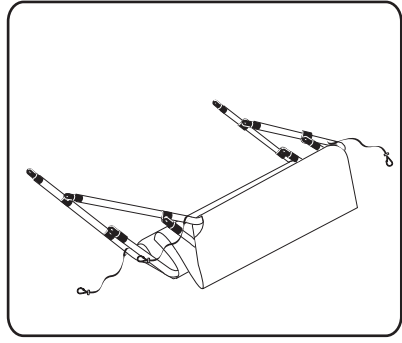

11 Remove screws from remaining jaw slide of Bow 1. Thread screw through jaw slide and Bow 2 eye end and secure to connect. Eye ends will rotate to line up.

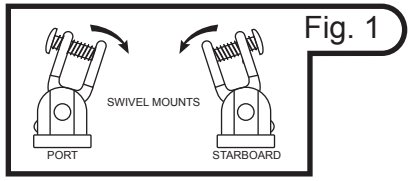
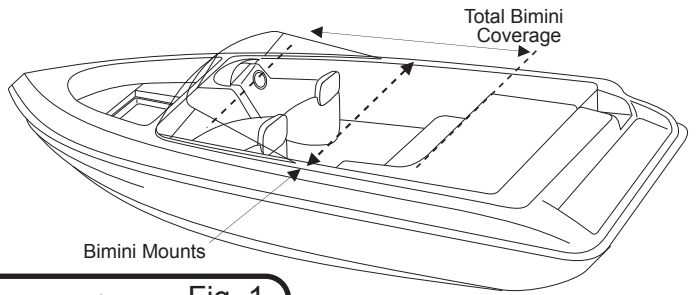

12 Determine what area of the boat you want to cover with the bimini. Bimini swivel mount locations are approximately half the distance of the total length of the bimini. Measure for mount placement and mark. Make sure the swivel mounts are parallel to each other and facing with the swivel movement going toward inside of boat (See Fig.1).

Use a 9/64" drill bit with mild pressure to carefully drill holes in boat deck for swivel mounts. Secure mounts with #8x5/8" mounting screws.

Remove single screws from top of swivel mount. With the help of a friend, each hold a side of the bimini and line up eye ends on Bow 1 with the swivel mounts keeping the label at the back. Secure eye ends to swivel mounts with previously removed screws facing as shown in Fig.1.

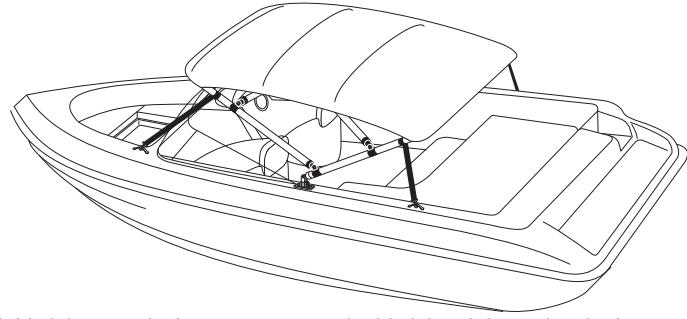

13 With bimini secure in the mounts, open the bimini and determine the best position for the hold down strap eyes. Strap eyes should be mounted to a flat surface whenever possible and straps should maintain an angle between 30 and 60 degrees from front to rear. To minimize side to side movement, it is suggested to mount front strap eyes as far inboard as allowable. Line up strap eyes across the boat.

Drill mounting screw holes for strap eyes in a similar fashion to the holes for the swivel mounts and secure eyes to the boat using the #8x5/8" screws. Clip hold down straps to the strap eyes and adjust tension so that the front of your bimini is level or lower than the rear, as this will allow air to travel over your top more effectively. Enjoy your new bimini!

Westland Industries is not responsible for any injuries to persons or damages to the boat during assembly and installation of this product. Installation of this product may void your boat warranty, check with your dealer. Replace any worn parts to increase the life of your product. Do not exceed speeds of 45 mph with bimini in upright position or damage may occur.



Install video



WESTLAND LIMITED CONSUMER WARRANTY

All warranty inquiries must first be addressed with the retailer or dealer from which the Westland product was originally purchased. Do not return product directly to Westland without an RA number. No returns will be accepted without a RA number.

Westland Industries warrants, to the original purchaser, that its products are free from defects in material and workmanship for the periods listed below:

Accessories: A 90 day warranty covering manufacturer defects applies to all accessories.

Bimini Frames: A 1 year warranty covering manufacturer defects applies to bimini frames.

Covers and Bimini Skins: Any Westland Industries cover proven defective will be repaired on a labors/materials basis or replaced on a prorated schedule dependent upon cover fabric (shown below) based on the retail price of the cover.

Sharkskin (3 year Warranty) 6 month free replacement	Sharkskin Plus (5 Year Warranty) 12 month free replacement
7-12 months—50% off invoice purchase price	13-20 months—60% off invoice purchase price
13-18 months—40% off invoice purchase price	21-30 months—40% off invoice purchase price
19-24 months—20% off invoice purchase price	31-50 months—30% off invoice purchase price
	51-60 months—20% off invoice purchase price

Sharkskin Supreme SD (7 Year Warranty) 24 month free replacement	Sunbrella (10 Year Warranty) 24 month free replacement	
25-36 months—60% off invoice purchase price	25-36 months—60% off invoice purchase price	37-48 months—50% off invoice purchase price
37-48 months—50% off invoice purchase price	49-60 months—40% off invoice purchase price	61-72 months—30% off invoice purchase price
49-60 months—40% off invoice purchase price	73-84 months—20% off invoice purchase price	85-96 months—15% off invoice purchase price
61-72 months—30% off invoice purchase price	97-120 months—10% off invoice purchase price	

Warranty Conditions

Retailer Receipt or Proof of Purchase must be presented for any warranty transaction. Please keep your receipt and any tags removed from your products. Warranty takes effect from date of initial retail purchase. The original purchase date must be clearly displayed on the purchase receipt.

Warranty Items Not Covered

Not covered under warranty is damage caused by misuse, accident, neglect, improper installation (this includes damage by allowing straps to whip against the side of the boat) or maintenance. Warranty is void if your product is contaminated with tree sap, improper chemicals, bleach, gasoline, oils and other liquids not defined to be part of the normal cleaning procedure.

Additional items not covered include damage as a result of animals such as rodents, birds, pets, insects, etc. Product is also not covered if any damage is incurred as a result of coming into contact with sharp objects that would result in punctures or tears. Acid rain and exposure to other pollutants may also void warranty.

Do not allow water, snow, or ice to pool on product as this will degrade the cover's water repellency and potentially cause mildew or premature leakage.

DAMAGED FOR POOLED WATER MAY NOT BE COVERED UNDER THIS WARRANTY.

To prevent this from occurring, it is **highly recommended** that you install a Westland vented boat pole (#5007-5) or standard boat pole (5010AP) to raise the center of your cover so water, snow and ice run off and do not collect. The Westland vented boat pole will also prolong the life of your cover, as well as help protect your boat's interior from mildew.

All incidental and/or consequential damages are excluded from the warranty. Implied warranties are limited to the life of the warranty. Some states do not allow limitations on how long an implied warranty lasts or the exclusion of incidental or consequential damages, so the above limitations may apply. This warranty gives you specific legal rights. You may also have other legal rights which typically vary from state to state.