



Go Power! Manual

GP-2500 GP Inverter

GP-1750 GP Inverter



Go Power! Electric Inc.
PO Box 6033
Victoria, BC V8P 5L4
Tel: 866-247-6527
Fax: 866-607-6527
Email: info@gpelectric.com



Table of Contents

1.	INTRODUCTION.....	3
2.	SPECIFICATIONS	3
3.	FEATURES.....	4
4.	INSTALLATION.....	7
5.	OPERATION.....	10
6.	OPERATING LIMITS.....	11
7.	TROUBLESHOOTING	12
8.	MAINTENANCE.....	13
9.	WARRANTY	13
10.	RV SUPPLEMENT.....	13

**Go Power! Electric Inc.
PO Box 6033
Victoria, BC V8P 5L4
Toll Free Tel: 866-247-6527
Toll Free Fax: 866-607-6527
Email: info@gpelectric.com**

1. Introduction

The Go Power! Inverter series provides mobile power for people on the go. Run standard AC appliances wherever you travel. Silent, lightweight and simple to use, Go Power! Inverters can be used in a wide range of applications including remote homes, RVs, boats and long haul trucks. It will operate most televisions and VCR's, personal computers and small appliances including drills, sanders, grinders, mixers, blenders and microwaves.

To get the most out of your power inverter, it must be installed and used properly. **Please read the instructions in this manual before installing and using your inverter.**

2. Specifications

2.1 GP2500 Inverter

12V

Output	2500 W
Output wave form	Modified Sine Wave
Output voltage	120 ± 5 VAC
Regulation	± 5%
DC input voltage	10-15 V
Low battery alarm	10.5V ± 0.5%
Low battery shut-down	10V ± 0.5%
Efficiency	85-90%
Frequency ±1%	60 Hz
No load current	0.77 A
Surge rating	3600 W
Over thermal protection	Yes
Two Cooling fans - continuous	Yes
Overload protection	Yes
Dimensions (LxWxH)	475 x 242 x 89 mm
Net weight	6 KG
Inverter Install Kit	GP-DC-Kit 4

2.2 GP1750 Inverter

12V

Output	1750 W
Output wave form	Modified Sine Wave
Output voltage	115 VAC
Regulation	± 5%
DC input voltage	10-15 V
Low battery alarm	10.7 V ± 0.2
Low battery shut-down	10V ± 0.2
Efficiency	85-90%
Frequency ±1%	60 Hz
No load current	0.43 A
Surge rating	2100 W
Over thermal protection	Yes
Cooling fan - continuous	Yes
Overload protection	Yes
Dimensions (LxWxH)	395 x 240 x 90 mm
Net weight	4 KG
Inverter Install Kit	GP-DC-Kit 3

3. Features

3.1 Front view – GP2500

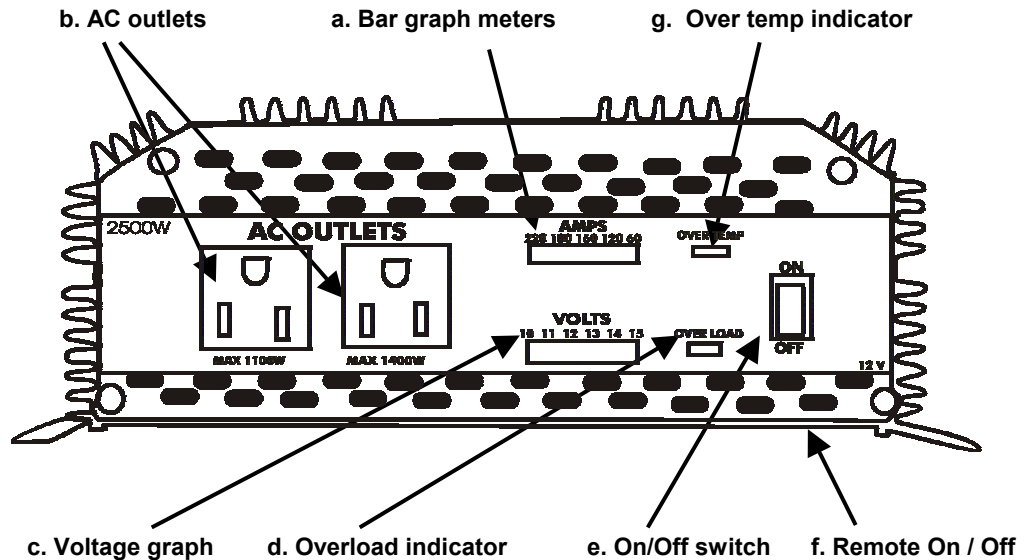

- a) Bar graph meters:
Display battery voltage and current. Current should be in the green zone for continuous operation. The inverter will operate for several minutes when the current is in the yellow zone.

Operation with battery voltage or current in the red zone of a meter will result in protective shutdown of inverter.
- b) AC outlet:
Outlet sockets available: North America

See RV supplement if wiring to breaker panel.
- c) Voltage graph.
- d) Overload indicator:
Lights up when inverter shuts down due to overloading. Turn inverter OFF, remove cause of overload and turn inverter ON to reset.
- e) ON/ OFF switch:
Leave in the OFF position during installation.
- f) Remote ON/ OFF switch:
Leave in the OFF position during installation.
- g) Over Temp. indicator:
Lights up when inverter protects itself against overheating. Inverter shuts down while indicator is on. Inverter will restart automatically and indicator will turn OFF when the inverter cools.

3.2 Front view – GP1750

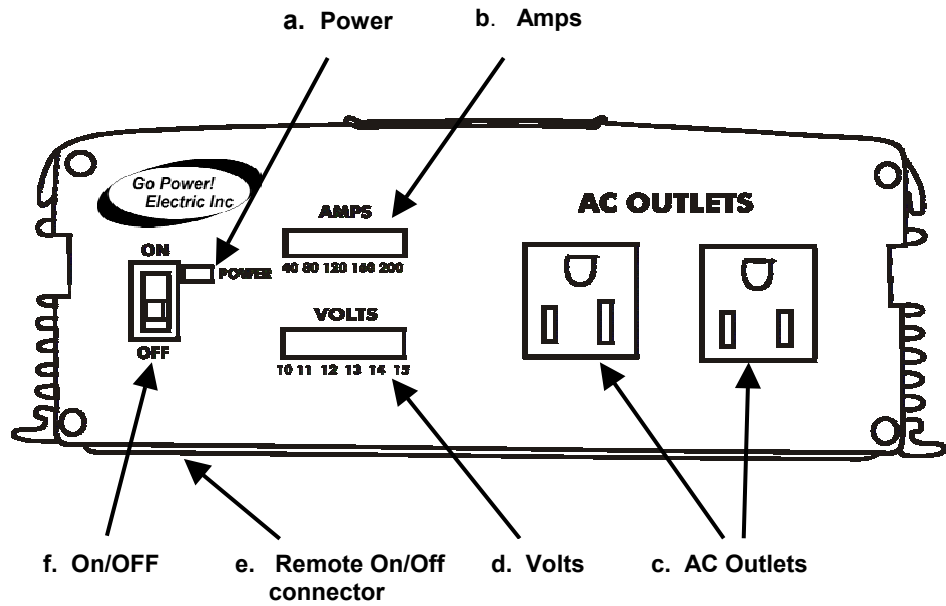

- a) Power:
Displays whether inverter power is on or off.
- b) Amps indicator:
- c) AC outlet:
Outlet sockets available: North America

See RV supplement if wiring to breaker panel.
- d) Volts indicator:
- e) Optional remote plug is on bottom of inverter.
- f) ON/ OFF switch:
Leave in the OFF position during installation.

3.3 Rear view – GP 2500

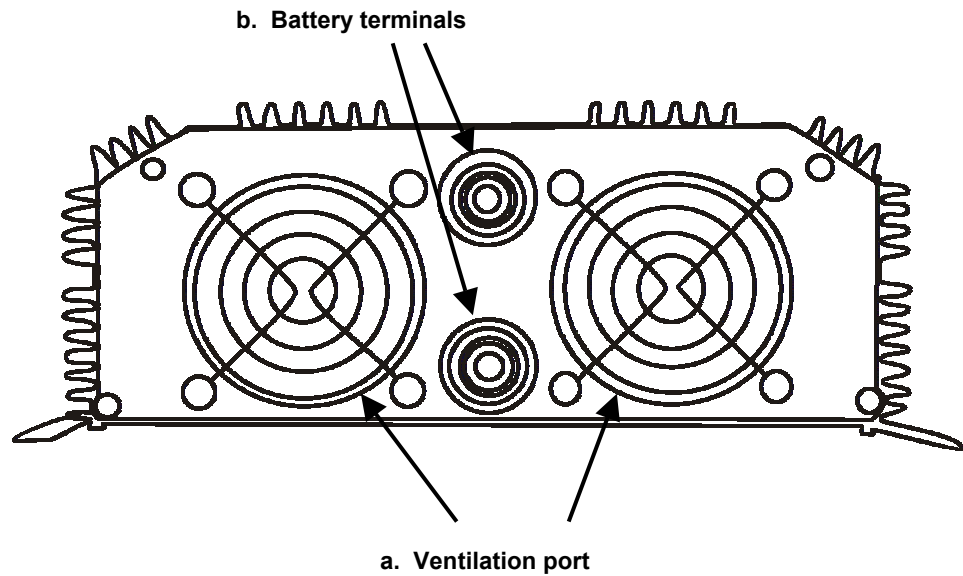

Warning!

Operation of the inverter without a proper ground connection may result in an electrical safety hazard.

- a) Ventilation port:
Do not obstruct, allow at least 1 inch for air flow.
- b) Battery terminals:
Connect to 12 V battery or other 12 V power source. Note that "+" is positive, "-" is negative. Reverse polarity connection will blow internal fuse and may damage inverter permanently.

3.4 Rear view – GP1750

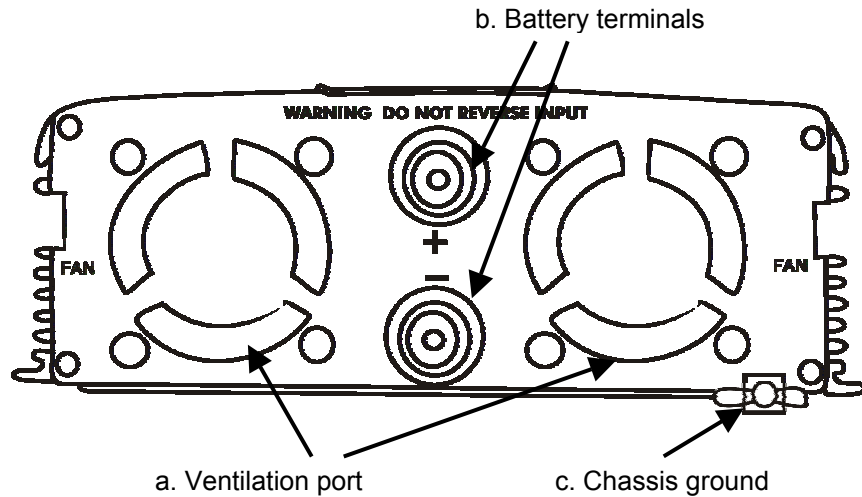

- a) Ventilation port:
Do not obstruct, allow at least 1 inch for air flow.
- b) Battery terminals:
Connect to 12 V battery or other 12 V power source. Note that "+" is positive, "-" is negative. Reverse polarity connection will blow internal fuse and may damage inverter permanently.
- c) Chassis ground lug:
Connect to earth ground or to vehicle chassis using #8 AWG wire.
*DC inverter cables not included

4. Installation

4.1 Where to install

The power inverter should be installed in a location that meets the following requirements:

- a) Dry - Do not allow water to drip or splash on the inverter.
- b) Cool - Ambient air temperature should be between 0°C and 40°C (the cooler the better).
- c) Ventilated - Allow at least two inches of clearance around the inverter for air flow. Ensure the ventilation openings on the rear and bottom of the unit are not obstructed.
- d) Safe - Do not install the inverter in the same compartment as batteries or in any compartment capable of igniting flammable liquids such as gasoline.
- e) Inverter should be located within 10 feet of the batteries.

4.2 Hook-up and testing

To hook-up the inverter please follow these guidelines:

Caution!

A reverse polarity connection will blow a fuse in the inverter and may permanently damage the inverter. Damage caused by reverse polarity connection is not covered by our warranty.

Warning!

You may observe a spark when you make this connection since current may flow to charge capacitors in the power inverter. Do not make this connection in the presence of flammable fumes, as explosion or fire may result

1. Unpack and inspect your Go Power! Inverter, check to see that the power switch is in the OFF position. We recommend using DC Install Kits whenever installing a GP Inverter.
2. When attaching the DC inverter cables to the power input terminals on the rear panel of the power inverter. The (+) terminal is positive and (-) terminal is negative. Connect the cables into the terminals by placing the lug connector between the washers and tighten the terminal screw or nut to clamp the wires securely. Ensure connections are tight.
3. First connect the cable from the negative terminal of the inverter to the negative terminal of the battery. Make a secure connection.
Caution! Loose connections result in excessive voltage drop and may cause overheated wires and melted insulation. Ensure connections are tight.
4. Before proceeding further, carefully check that the cable you have just connected going from the negative terminal of inverter to the negative output terminal of the power source (battery).
5. Install the inverter fuse into the positive lead. Fuse should be located within 12" of battery. Ensure all connections are tight and secure.
6. Connect the cable from the positive terminal of inverter to the positive terminal of the battery. Make a secure connection. Check your polarity.
7. Set the power switch to the ON position. Check the meters and indicators on the front panel of the inverter. The voltage bar graph should indicate 11 to 14 volts depending on the voltage of the power source. If it does not, check your battery bank and the connections to the inverter. The other indicators should be OFF.
8. Set the power inverter switch to the OFF position. The indicator lights may blink and the internal alarm may sound momentarily. This is normal. Plug the test load into the AC receptacle on the front panel of the inverter.
9. Set the power inverter switch to the ON position and turn the test load on; the inverter should supply power to the load. If you plan to measure the output voltage of the inverter, a true r.m.s. meter must be used for accurate readings.
10. Ensure battery interconnect cables are a minimum of #4 gauge wire and a maximum of 12" in length.

4.3 DC Kits

Go Power! DC Installation Kits include everything you will need to properly connect your Go Power! Inverter to the batteries.

- GP-2500 – Use GP Install Kit 4
- GP-1750, GP-SW1800-12 – Use GP Install Kit 3
- GP-1000, GP-SW600, GP-SW1800-24 - Use GP Install Kit 2



4.4 Cables

DC to AC inverters require high amperage to operate properly; connect inverter DC input terminals to battery with heaviest wire available. See chart below:

Max. Watts Out	Approx. Amps Req'd (12 VDC)	Wire Gauge
300 W	30 A	#10
600 W	60 A	#6
1000 W	100 A	#4
1500 W	150 A	#2 @ 10'
1500 W	150 A	#4 @ 5'
1750 W	175 A	#2 @ 10'
2500 W	250 A	2 / 0

*Cable length is not recommended to exceed 10 feet in length.

4.5 Inverter fuse

A class "T" inverter fuse should be included in all installations.

- GP 2500 - 300 amp fuse
- GP 1750 – 200 amp fuse
- GP 1000 – 110 amp fuse

Caution!

The negative DC input of the power inverter is connected to the chassis. Do not install the power inverter in a positive ground DC system. A positive ground DC system has the positive terminal of the battery connected to the chassis of the vehicle or to the grounding point.

Warning!

Do not operate the power inverter without connecting it to ground. Electrical shock hazard may result.

4.6 Grounding

The power inverter has a lug on the rear panel: "Chassis Ground." This is to connect the chassis of the power inverter to the ground. The ground terminals in the AC outlets on the front panel of the inverter are also connected to the ground lug. To ground the GP-2500, connect grounding wire to one of the mounting screws and sand the connection before attaching the wire.

The chassis ground lug must be connected to a grounding point, which will vary depending on where the power inverter is installed. In a vehicle, connect the chassis ground to the chassis of the vehicle. In a boat, connect to the boat's grounding systems. In a fixed location, connect the chassis ground lug to earth.

The neutral (common) conductor of the power inverter AC output circuit is not bonded to the chassis ground. Therefore, when the chassis is connected to ground, the neutral conductor will not be grounded.

At no point should the chassis ground and the neutral conductor of the inverter be bonded. Bonding the chassis ground and the neutral conductor of the inverter or connecting the inverter to household or recreational AC distribution wiring will damage the unit and void the warranty.

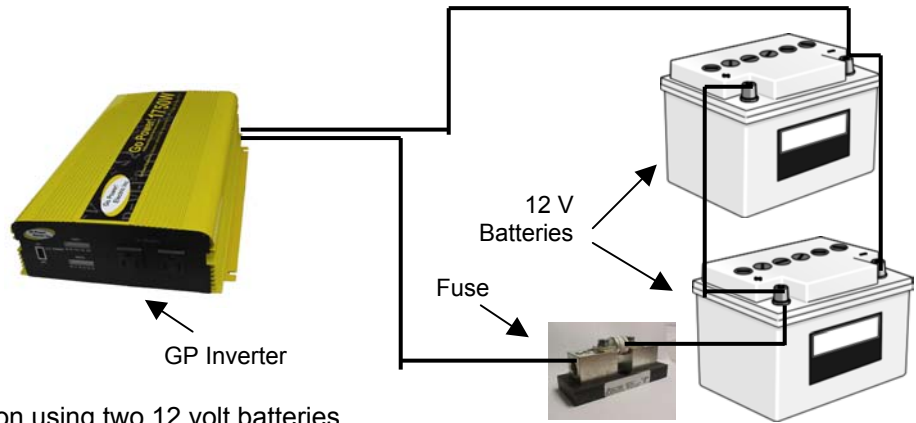

*Installation using two 12 volt batteries

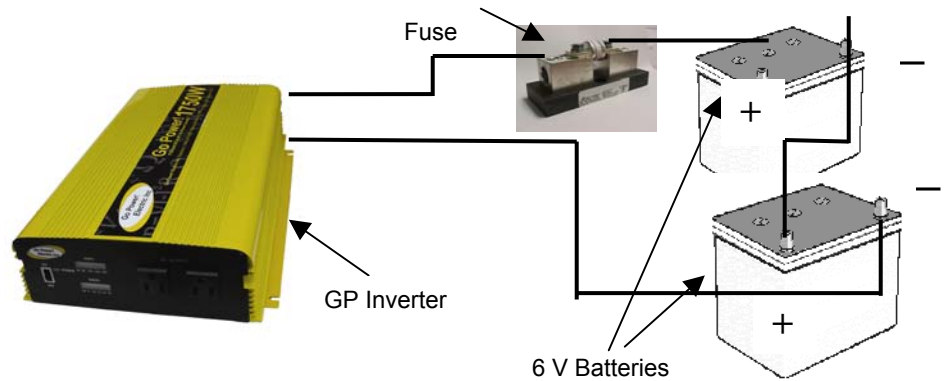

*Installation using two 6 volt batteries.

5. Operation

To operate the power inverter, turn it on using the ON/OFF switch on the front panel. The power inverter is now ready to deliver AC power to your loads. If you are operating several loads from the power inverter, turn them on separately after the inverter has been turned ON. This will ensure that the power inverter does not have to deliver the starting currents for all the loads at once.

5.1 Controls and indicators

The ON/OFF switch turns the control circuit in the power inverter ON and OFF. It does not disconnect power from the power inverter.

When the switch is in the OFF position, the power inverter draws no current from the battery. When the switch is in the ON position but with no load, the power idle current is approximately 1 A (see product specifications for exact current draw).

5.2 Optional On / Off remote

The optional remote switch can be used to turn the inverter on and off from a location up to 25 feet away. The inverter should be OFF when plugging remote in. Once the remote is installed the inverter ON/OFF switch must be in the ON position.

5.3 Battery voltage indicator

The battery voltage bar graph indicates the voltage at the input terminals of the power inverter. At low input current, this voltage is very close to the battery voltage. At high input current, this voltage will be lower than the battery voltage.

Ideally, the voltage should remain in the green areas of the bar graph. If the voltage goes into the red area at the top or bottom of the graph, the inverter may shut-down.

5.4 Battery current indicator

The battery current bar graph indicates the current drawn from the battery by the power inverter. It will not indicate current by other loads also connected to the battery.

For long-term operation, the current should be in the green area of the bar graph. Short-term operation is possible with current in the yellow area. If the current rises to the red area, the inverter will reduce its output to protect itself.

5.5 Overtemp indicator

The overtemp indicator indicates that the power inverter has shut itself down because the inverter has become overheated. The power inverter may overheat because it has been operated at power levels above its rating, or because it has been installed in a location which does not allow it to dissipate heat properly. The power inverter will restart automatically once it has cooled off.

5.6 Overload indicator

The overload indicator indicates that the power inverter has shut itself down because its output circuit has been short circuited or drastically overloaded. Switch the ON/OFF switch to OFF, correct the fault condition, and then switch the ON/OFF switch back to ON.

6. Operating limits

6.1 Power output

The inverter will operate most AC loads within its power rating. When determining whether a microwave oven can be operated by the GP-1750 Inverter, remember that the power commonly advertised for microwave ovens is the cooking power (the power delivered to the food) not the power actually consumed by the microwave oven. The microwave oven will consume 40% to 100% more than its advertised cooking power. Check the rating sticker on the back of the oven to determine its actual power draw. The GP-1750 inverter will operate small microwave ovens (0.2 to 0.3 cubic foot capacity) that draw about 1700 watts. It will provide 10 to 45 minutes of cooking time.

Some induction motors used in refrigerators, freezers, pumps and other motor operated equipment require very high surge currents to start. The power inverter may not be able to start some of these motors, even though their rated current draw is within the power inverter.

If the motor refuses to start, observe the battery voltage indicator while trying to start the motor. If the battery voltage indicator drops below 11 volts while the inverter is attempting to start the motor, this may be why the motor will not start. Make sure that the battery connections are good and that the battery is fully charged. If the connections are good and the battery is charged, but the voltage still drops below 11 volts, you may need to use a larger battery.

6.2 Input voltage

The power inverter will operate from input voltage ranging 10 V – 15 V. If the voltage drops below 10.7 V, an audible low battery warning will sound and the voltage indicator will be in the lower red zone. The power inverter will shut down if the input voltage drops below 10 V. This protects your battery from being over discharged.

The power inverter will also shut down if the input voltage exceeds 15 V. This protects the inverter against excessive input voltage. The voltage indicator will be in the upper red zone. Although the power inverter incorporates protection against overvoltage, it may still be damaged if the input voltage is allowed to exceed 20 V.

7. Troubleshooting

7.1 Common problems

Note: There are audible low voltage / over load alarms on all inverters.

- a) Buzz in audio systems
Some inexpensive stereo systems will emit a buzzing noise from their loudspeakers when operated from the power inverter. This is because the power supply in the device does not adequately filter the modified sine wave produced by the power inverter. The only solution is to use a sound system that incorporates a higher quality power supply.

- b) Television interference
Operation of the power inverter can interfere with television reception on some channels. If this situation occurs, the following steps may help to alleviate the problem.
 - Make sure that the chassis ground lug on the back of the power inverter is solidly connected to the ground system of your vehicle, boat or home. With the exception of the GP-2500 which would connect to one of the mounting screws.
 - Do not operate high power loads with the power inverter while watching television.
 - Make sure that the antenna feeding your television provides an adequate ("snow free") signal and that you are using good quality cable between the antenna and the television.
 - Move the television as far away from the power inverter as possible.
 - Keep the cables between the battery and the power inverter as short as possible and twist them together with about 2 to 3 twists per foot. This minimizes radiated interference from the cables.

7.2 Troubleshooting guide

Problem and Symptoms	Possible Cause	Solution
Low AC output voltage 95-105 VAC	Using standard voltmeter	Use true RMS averaging meter.
Low output voltage and current indicator in red zone	Overload	Turn off. Reduce load, turn on.
No output voltage and voltage indicator in lower red zone	Low DC input voltage	Recharge battery, check connections and cable.
No output voltage, no voltage	Inverter switched off.	Turn inverter on. Check



indication	No power to inverter.	wiring to inverter.
	Internal fuse open	Have qualified service technician check and replace.
	Reverse DC polarity	Have qualified service technician check and replace fuse, OBSERVE CORRECT POLARITY.
No output voltage, voltage indicator in upper red zone	High input voltage	Make sure that inverter is connected to 12 V battery. Check regulation of charging system.
Low battery alarm on all the time, voltage indicator below 11 V	Poor DC wiring, poor battery condition.	Use proper cable and make solid connections. Use new battery.
No output voltage, Over Temp indicator on, load in excess of: 2500 W: 210 A 1500 W: 145 A	Thermal shutdown	Allow inverter to cool off. Reduce load if continuous operation required.
No output voltage, Over Temp indicator On, load less than: 2500 W: 210 A 1500 W: 145 A	Thermal shutdown	Improve ventilation, make sure ventilation openings in inverter are not obstructed, reduce ambient temperature.
No output voltage, Over Load indicator on	Short circuit or wiring error. Very high power load	Check AC wiring for short circuit or improper polarity (hot and neutral reversed). Remove load.

8. Maintenance

Very little maintenance is required to keep your inverter operating properly. You should clean the exterior of the unit periodically with a dry cloth to prevent accumulation of dust and dirt. At the same time, tighten the screws on the DC input terminals.

9. Warranty

We warrant this product against defects in materials and workmanship for a period of 12 months from the date of purchase and will repair or replace any defective Go Power! Inverter when directly returned, postage prepaid, to the manufacturer. This warranty will be considered void if the unit has suffered any obvious physical damage or alteration either internally or externally, and does not cover damage arising from improper use such as plugging the unit into an unsuitable power sources, attempting to operate products with excessive power consumption requirements, reverse polarity, or use in unsuitable climates.

This is the only warranty and the company makes no other warranties, express or implied, including warranties of merchantability and fitness for a particular purpose. Repair or replacement are your sole remedies and shall not be liable for damages, whether direct, incidental, special or consequential, even though caused by negligence or other fault.

10. RV Supplement

10.1 Installing the GP 2500, GP 1750, and without an automatic

transfer switch

- Plug main power cord into inverter (a 15 amp adapter may be required).
- Battery inter-connects should be a minimum of 4 gauge.
- Ensure converter is turned Off when plugging into inverter.
- To avoid hidden loads turn inverter off when power is not required.

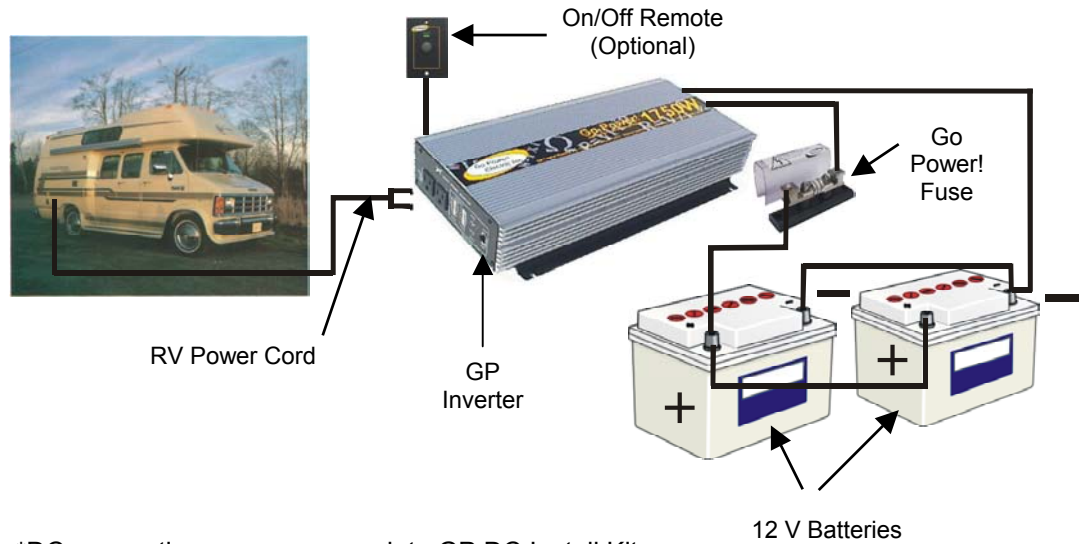

*DC connections – use appropriate GP DC Install Kit.

10.2 Installing the GP 2500, GP 1750, and with an automatic transfer switch

- Battery inter-connects should be a minimum of 4 gauge.
- Ensure converter is turned Off when inverter is operating.
- To avoid hidden loads turn inverter off when power is not required.

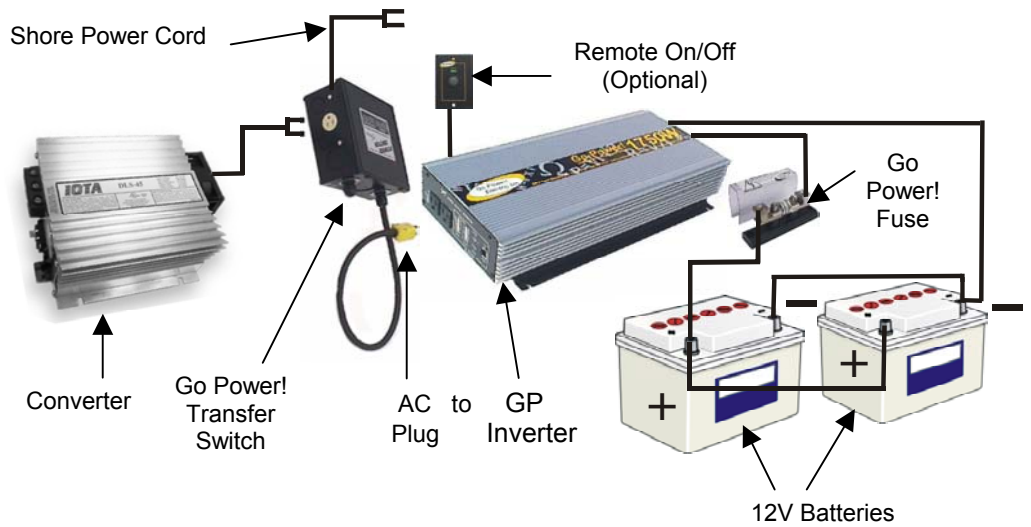

*DC connections – use appropriate GP DC Install Kit.