

DUAL-FLEX MARINE & INDUSTRIAL ENGINE VIBRATION ISOLATORS DF-2200 SERIES

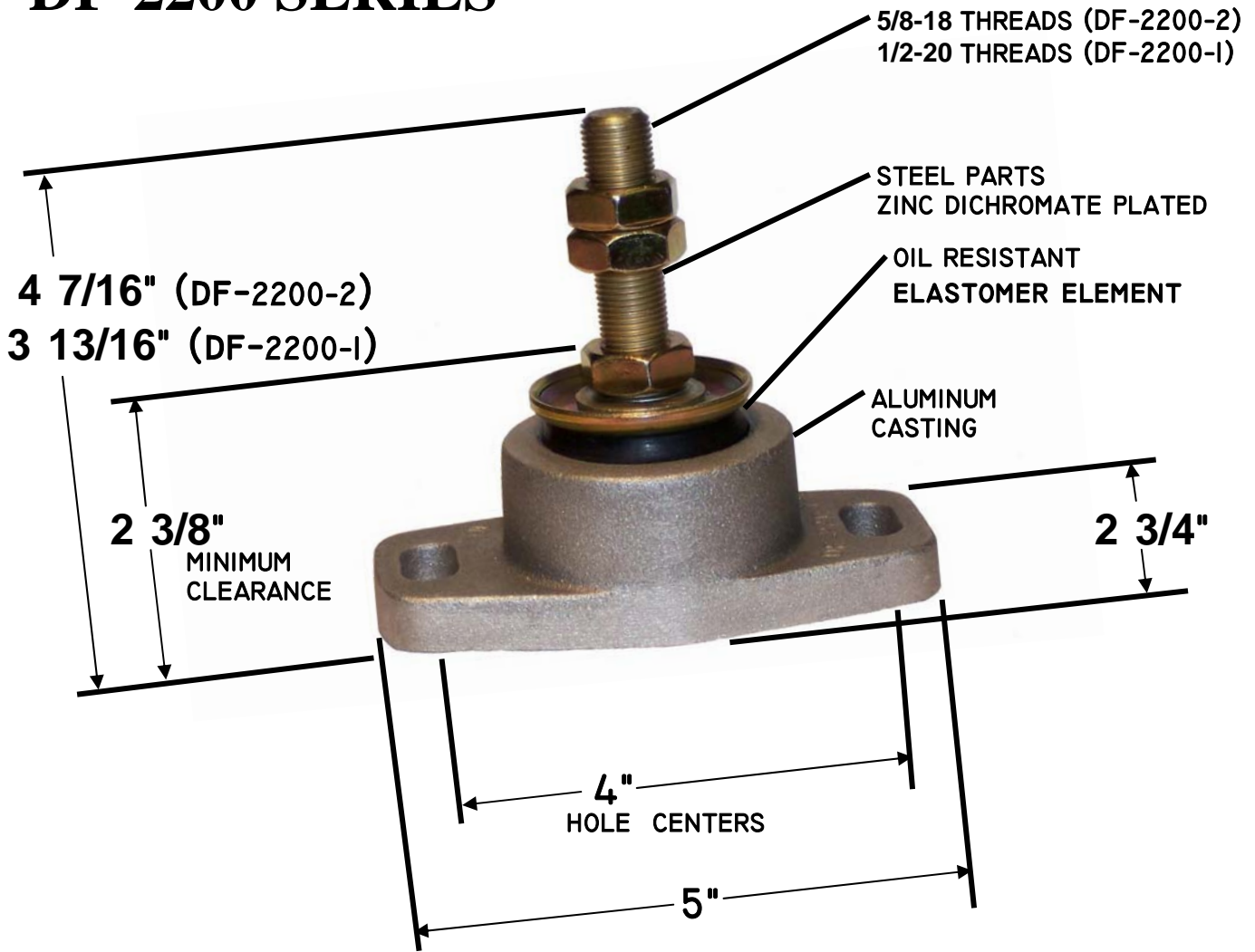

Manufactured in U.S.A.

DF-2200 SERIES

The ("Dual Flex") DF-2200 Series features heavy duty aluminum alloy construction with lip incorporated in the top of the casting to resist the upward pull of the engine. Durable oil and fuel resistant elastomer element raised above top of the casting to accommodate engine mounting angles. Low profile mount-requires only 2 3/8" minimum clearance from casting base to top of leveling nut. Fail safe design - bottom pad prevents excessive impact. Easy installation with threaded stud for vertical height and slotted casting for horizontal adjustment. Stud furnished with three nuts. Leveling, locking and

secondary lock. Aluminum base cast with 3/8” slotted holes for 3/8” bolts or lag screws. All steel parts are zinc dichromate plated for corrosion resistance. Available with 5/8” stud or 1/2” stud, and three size ratings dependant on engine/powertrain package weight.

SUGGESTED 4 POINT MOUNTINGS		
ENGINE WEIGHTS	5/8” STUD	1/2” STUD
Up to 150 lbs.	DF-2204-2	DF-2204-1
150 to 450 lbs.	DF-2205-2	DF-2205-1
450 to 750 lbs.	DF-2207-2	DF-2207-1

The Bushings, Inc. “Dual Flex” Marine Engine Mount design provides outstanding vibration isolation control across the three (longitudinal, lateral, and vertical) fields of vibratory motion. Construction of the mount gives a soft cushioning effect under normal loads, as mount loads increase across the operating range, shear resistance grows quickly providing smooth operation with a small amount of deflection.



BUSHINGS, INC.

**1967 Rochester Industrial Drive
 Rochester Hills, Michigan 48309-3340
 Phone:(248)650-0603 Fax:(248)650-0606
 www.bushingsinc.com**

