

---

---

INSTRUCTION AND PARTS MANUAL  
**MODEL H12**  
PLANETARY HYDRAULIC WINCH



**THE LOGICAL CHOICE**

**PULLMASTER WINCH CORPORATION**  
8247-130th Street, Surrey, B.C. V3W 7X4, Canada  
Telephone: 604-594-4444 Fax: 604-591-7332  
Website: [www.pullmaster.com](http://www.pullmaster.com)  
E-mail: [sales@pullmaster.com](mailto:sales@pullmaster.com)



**READ THIS MANUAL BEFORE INSTALLING, OPERATING OR SERVICING THIS PRODUCT. THIS MANUAL CONTAINS IMPORTANT INFORMATION. MAKE THIS MANUAL AVAILABLE TO ALL PERSONS RESPONSIBLE FOR THE OPERATION, INSTALLATION, SERVICING AND MAINTENANCE OF THIS PRODUCT.**

# PULLMASTER LIMITED WARRANTY

Effective 1/1/2002

*SUPERSEDES ALL PRIOR WARRANTIES*

Seller warrants that each article sold under this order shall at the time of shipment (i) conform to applicable specifications, and (ii) be free from defects in material and workmanship during normal and ordinary use and service (the "Warranty").

Buyer's exclusive remedy and Seller's sole obligation under this Warranty shall be, at Seller's option, to repair or replace any article or part thereof which has proven to be defective, or to refund the purchase price of such article or part thereof.

This Warranty shall expire one (1) year from the date the article is first shipped by Seller. Notice of claimed breach of this Warranty must be given by Buyer to Seller within the applicable period. Such notice shall include an explanation of the claimed warranty defect and proof of date of purchase of the article or part thereof for which warranty coverage is sought. No allowances shall be made by Seller for any transportation, labor charges, parts, "in and out" costs, adjustments or repairs, or any other work, unless such items are authorized in writing and in advance by Seller. Nor shall Seller have any obligation to repair or replace items which by their nature are expendable.

If an article is claimed to be defective in material or workmanship, or not to conform to the applicable specifications, Seller will either examine the article at Seller's site or issue shipping instructions for return to Seller. This Warranty shall not extend to any articles or parts thereof which have been installed, used, or serviced otherwise than in conformity with Seller's applicable specifications, manuals, bulletins, or instructions, or which shall have been subjected to improper installation, operation, or usage, misapplication, neglect, overloading, or employment for other than normal and ordinary use and service.

This Warranty shall not apply to any articles or parts thereof furnished by Seller to Buyer's specifications and/or furnished by Buyer or acquired from others at Buyer's request.

SELLER MAKES NO EXPRESS WARRANTIES AND NO IMPLIED WARRANTIES OF ANY KIND, OTHER THAN THE WARRANTY EXPRESSLY SET FORTH ABOVE. SUCH WARRANTY IS EXCLUSIVE AND IS MADE AND ACCEPTED IN LIEU OF ANY AND ALL OTHER WARRANTIES, EXPRESS OR IMPLIED, INCLUDING WITHOUT LIMITATION THE IMPLIED WARRANTIES OF MERCHANTABILITY AND FITNESS FOR A PARTICULAR PURPOSE.

The remedies for this Warranty shall be only those expressly set forth above, to the exclusion of any and all other remedies of whatsoever kind. The limited remedies set forth above shall be deemed exclusive, even though they may fail their essential purpose. No agreement varying or extending the foregoing Warranty, remedies, exclusions, or limitations shall be effective unless in a writing signed by an executive officer of Seller and Buyer. This Warranty is non-transferable.

Under no circumstances shall Seller be liable (i) for any damage or loss to any property other than the warranted article or part thereof, or (ii) for any special, indirect, incidental, or consequential damage or loss, even though such expenses, damages, or losses may be foreseeable.

The foregoing limitations on Seller's liability in the event of breach of warranty shall also be the absolute limit of Seller's liability in the event of Seller's negligence in manufacture, installation, or otherwise, with regard to the articles covered by this Warranty, and at the expiration of the Warranty period as above stated, all such liabilities shall terminate.



## WARNING

**PULLMASTER** planetary winches/drives are not designed for operations involving lifting or moving personnel. The **PULLMASTER WINCH CORPORATION** cannot be held liable or responsible for any accident resulting from such use of **PULLMASTER** planetary winches/drives.

**Note:** Specifications contained in this Instruction and Parts Manual are subject to change without notice.

# SAFETY RECOMMENDATIONS



**DANGER**

**FAILURE TO COMPLY WITH THE FOLLOWING SAFETY RECOMMENDATIONS AND LOCAL RULES AND REGULATIONS WILL RESULT IN PROPERTY DAMAGE, SEVERE INJURY OR DEATH.**



Definition: **Caution** indicates a potentially hazardous situation which, if not avoided may result in minor or moderate injury.



Definition: **Warning** indicates a potentially hazardous situation which, if not avoided could result in death or serious injury.



Definition: **Danger** indicates a potentially hazardous situation which, if not avoided will result in death or serious injury.

The planetary hydraulic winches are made for hoisting and lowering loads and to be operated by trained and professional personnel. They are not designed for operations involving lifting or moving personnel. The winches are powered by hydraulic power. The ropes / cables for hoisting operations are not supplied by PULLMASTER. The winches are always assembled in an application, they do not function as an independent machine and it is not allowed to use them as such.

The winches are to be used within the specifications as listed in the manual under "SPECIFICATIONS". Other use as foreseen in the functional description of the hydraulic winch is not allowed without written permission from PULLMASTER.

1. Do not install, operate or service winch before reading and understanding manufacturer's instructions.
2. The winch described herein is not designed for operations involving lifting or moving personnel.
3. Do not lift or carry loads over people.
4. Do not exceed recommended operating pressure (psi) and operating volume (gpm).
5. Do not jerk the winch. Always smoothly accelerate and decelerate load.
6. Do not operate a damaged, noisy or malfunctioning winch.
7. Do not leave a load suspended for any extended period of time.
8. Never leave a suspended load unattended.
9. Winch should be maintained and operated by qualified personnel.
10. Inspect winch, rigging, mounting bolts and hoses before each shift.
11. Warm-up equipment before operating winch, particularly at low ambient temperatures.
12. Verify winch function by raising and lowering a full test load to a safe height before each shift.
13. Do not weld any part of the winch.
14. Verify gear lubrication and brake circulation supply and return before operating winch.
15. Be sure of equipment stability before operating winch.
16. Wear proper clothing to avoid entanglement in rotating machinery.
17. Always stand clear of the load.
18. Use only recommended hydraulic oil and gear lubricant.
19. Keep hydraulic system clean and free from contamination at all times.
20. Maintain winch and equipment in good operating condition. Perform scheduled maintenance regularly.
21. Keep hands clear when winding wire rope onto the winch drum.
22. Do not use the wire rope as a ground for welding.
23. Rig the winch carefully. Ensure that the wire rope is properly anchored to the correct cable anchor slot at the cable drum.
24. Do not lift a load with a twisted, kinked or damaged wire rope.
25. Consult wire rope manufacturer for size, type and maintenance of wire rope.
26. Maintain three wraps of wire rope on the cable drum at all times.
27. In case of a power failure or breakdown leading to an unexpected stop of the hydraulic power circuit, stand clear of the area and the load being hoisted, take the necessary precautions to prevent access to area where the load is halted.
28. The noise level of the winch is 86 dBA measured on a distance of 1.00 meter, 1.60 meters high. The measuring equipment used was: Realistic#42-3019.
29. Clean up any oil spillage immediately.
30. Wear proper clothing and personal protection equipment such as, footwear, safety goggles and a hard hat. Read manual first.



# DESCRIPTION OF THE MODEL H12

## GENERAL DESCRIPTION:

The PULLMASTER Model H12 is a planetary, hydraulic winch with reversing or lowering speed 4.3 times faster than forward or hoisting speed. The main components of this unit are:

- + Hydraulic gear motor
- + Multi-disc brake with static and dynamic function
- + Primary planet reduction
- + Final planet reduction
- + Brake housing
- + Final drive housing
- + Cable drum

## FUNCTION IN FORWARD ROTATION (HOISTING):

In forward rotation, the output torque and rpm of the hydraulic motor are transmitted to the sun gear of the primary planet reduction. The output torque and rpm of the primary reduction stage are transmitted to the final reduction stage by the final sun gear shaft, which is splined to the primary planet hub. In forward rotation, or when a load is raised, an over-running clutch, which connects the motor drive shaft to the automatic brake assembly, permits free rotation of the sun gear without effecting the brake. When the winch rotation is stopped, the load on the cable drum causes the over-running clutch to lock and the maximum load is held safely by the disc brake.

## FUNCTION IN REVERSE ROTATION (LOWERING):

In reverse rotation, hydraulic pressure from the reversing side of the hydraulic motor is channelled to the brake piston, causing the brake piston to release the multi disc brake against a number of brake springs. The over-running clutch, connecting the motor drive shaft with the internal gear of the primary planet reduction locks, causing the internal gear to rotate at the same rpm as the primary sun gear. Thus, the primary reduction stage is eliminated and the output torque and rpm of the hydraulic motor are transmitted directly to the final planet reduction stage. With the primary reduction stage eliminated, the reduction is reduced to a ratio of 9.5:1 and the cable drum will rotate 4.3 times faster than in forward or hoisting speed.

If the load on the cable drum tends to effect the lowering speed, the resulting pressure drop in the brake piston causes friction between the brake discs and divider plates. In this way a completely smooth lowering speed can be achieved in a stepless operation by modulation of the winch control handle. When the control handle is returned to neutral position, rotation stops and the disc brake applies automatically.

During the lowering operation of the winch, the friction created by the brake discs results in temperature. This temperature is dissipated by an internal circulation flow, supplied out of the hydraulic motor, or from an external source. For models with external circulation, required flow is approx. 4.5 (US) gpm - 17 l/min. The circulation return line must go to the reservoir directly.

**IMPORTANT:** Under no circumstances must the back pressure in the brake housing be permitted to exceed 30 psi (2 bar). Excessive pressure in the brake housing will damage the oil seal separating the brake housing from the drum interior. Damage to this seal will cause the drum to fill up with hydraulic fluid. In order to prevent potential damage to the drum seals and the end cover of the winch, when the cable drum fills up with hydraulic fluid, a breather relief (see PARTS REFERENCE, item 130) is installed on the end cover. The breather relief bleeds to atmosphere and serves as a warning signal that the oil seal between the brake housing and drum has been damaged.

# EXPLANATION OF MODEL CODING

**H 12 X - XX - XX - XX X - X XXXX**

**BASIC UNIT SERIES**

H = Rapid reverse

**SIZE OF UNIT**

**REDUCTION RATIO**

Only used for non standard reduction ratios

**TYPE OF BRAKE**

- 3 Automatic brake, clockwise drum rotation, internal circulation flow
- 4 Automatic brake, external brake release, clockwise drum rotation, internal circulation flow
- 5 Automatic brake, external brake release, counterclockwise drum rotation, internal circulation flow
- 6 Automatic brake, counterclockwise drum rotation, internal circulation flow
- 7 Automatic brake, clockwise drum rotation, external circulation flow
- 8 Automatic brake, external brake release, clockwise drum rotation, external circulation flow
- 9 Automatic brake, external brake release, counterclockwise drum rotation, external circulation flow
- 10 Automatic brake, counterclockwise drum rotation, external circulation flow

**HYDRAULIC MOTOR**

- 97 *WM51* hydraulic motor, 2 inch gear section  
(Other gear sections for this motor are optional)

**DRUM SIZE**

- 1 7 5/8 inch drum diameter X 14 5/8 inch flange diameter X 10 inch length - STANDARD  
(For other drum sizes refer to APPENDIX A)

**OPTIONS**

- F Hydraulically actuated **freespooling**

**DESIGN REVISION**

**SPECIFICATION NUMBER**

Describes features not identified by preceding codes

**NOTE:** Clockwise and counterclockwise drum rotation is the direction of rotation for pulling or hoisting, established by looking at the hydraulic motor.

# OPTIONS

## COUNTERCLOCKWISE ROTATION:

The drum rotation of the standard PULLMASTER Model H12 planetary winch is clockwise for hoisting when looking at the hydraulic motor of the winch. Drum rotation for counterclockwise hoisting direction is available as an option.

## EXTERNAL BRAKE RELEASE:

PULLMASTER planetary winches can be supplied with an **external brake release** which permits release of the automatic disc brake from an external pressure source.



**FAILURE TO PROPERLY VENT EXTERNAL BRAKE RELEASE PORT WILL TRAP BRAKE PRESSURE AND ALLOW THE LOAD TO DROP, CAUSING PROPERTY DAMAGE, SEVERE INJURY OR DEATH. WINCHES SUPPLIED WITH EXTERNAL RELEASE OPTION MUST BE CONNECTED ACCORDING TO TYPICAL HYDRAULIC CIRCUIT.**

## CABLE DRUM SIZES:

Aside from the standard drum sizes listed in APPENDIX A, the PULLMASTER Model H12 planetary winch can be supplied with optional drums to accommodate large wire rope storage capacity.

## DRUM GROOVING:

Cable drums for the PULLMASTER Model H12 planetary winch can be grooved. Where this option is a requirement, it is necessary to state the size of wire rope which is to be used with the winch.

## OPTIONAL GEAR SECTION FOR THE HYDRAULIC MOTOR:

The performance of the standard PULLMASTER Model H12 planetary winch may be changed by using a different displacement motor. (Contact the factory for performance information.)

## HYDRAULIC MOTORS FOR HIGH PRESSURE HYDRAULIC SYSTEMS:

The operating pressure of the standard PULLMASTER Model H12 planetary winch is limited to 2200 psi (152 bar). For hydraulic systems operating with a higher range of hydraulic pressure, the winch can be supplied with a hydraulic piston motor, which will provide for the same basic performance in terms of line pull and line speed capacity. (Contact the factory for this requirement.)

## FREESPOOLING:

This option permits wire rope being pulled off the cable drum by an operator. **Freespooling** should not be confused with **free fall**. The **freespool** mechanism cannot be disengaged or re-engaged with a load on the wire rope or while the cable drum is turning.

**NOTE:** Freespooling is available for standard reduction only.

The PULLMASTER WINCH CORPORATION will consider other options for quantity requirements.

# SPECIFICATIONS

Performance specifications are based on standard hydraulic motor, gear ratio and cable drum with 5/8 inch diameter wire rope. For other cable drums refer to APPENDIX A. For other reductions or motors, refer to supplement inside back cover. Performance specifications for winches supplied with optional motors are provided in attached supplement.

## CABLE DRUM DIMENSIONS (STANDARD DRUM):

Barrel diameter	7.63 in	194 mm
Flange diameter	14.63 in	371 mm
Barrel length	10.00 in	254 mm

## CABLE STORAGE CAPACITY:

<b>(Size of wire rope)</b>	1/4 in	1280 ft	390 m
	5/16 in	793 ft	242 m
	3/8 in	569 ft	173 m
	7/16 in	458 ft	140 m
	1/2 in	307 ft	94 m
	9/16 in	287 ft	87 m
	5/8 in	222 ft	68 m

**MAXIMUM OPERATING PRESSURE:** 2200 psi 152 bar

**MAXIMUM OPERATING VOLUME:** 50 (US) gpm 189 l/min

**MINIMUM OPERATING VOLUME:** 17 (US) gpm 64 l/min

**DRUM TORQUE AT MAXIMUM PRESSURE:** 50,000 lb-in 5,649 Nm

**DRUM RPM AT MAXIMUM VOLUME:**  
 Hoisting 48 rpm  
 Lowering 208 rpm

## HOISTING LINE PULL AT MAXIMUM PRESSURE:

Bare drum	12,121 lb	53.9 kN
Full drum	7,143 lb	31.8 kN

## MAXIMUM ALLOWABLE LINE PULL WHEN LOWERING:

Bare drum	2,791 lb	12.4 kN
Full drum	1,702 lb	7.6 kN

## HOISTING LINE SPEED AT MAXIMUM VOLUME:

Bare drum	104 fpm	32 m/min
Full drum	176 fpm	54 m/min

## LOWERING LINE SPEED AT MAXIMUM VOLUME:

Bare drum	449 fpm	137 m/min
Full drum	762 fpm	232 m/min

**PERMISSIBLE SYSTEM BACK PRESSURE AT MOTOR RETURN PORT:** 65 psi 4.5 bar

**PERMISSIBLE PRESSURE AT CIRCULATION SUPPLY PORT:** 30 psi 2 bar

**LUBRICATING OIL:** Refer to RECOMMENDATIONS for viscosity and instructions.  
 Refer to APPENDIX A for oil volume required.

# PERFORMANCE GRAPHS

PG-H12-A

## LINE PULL VS. OIL PRESSURE

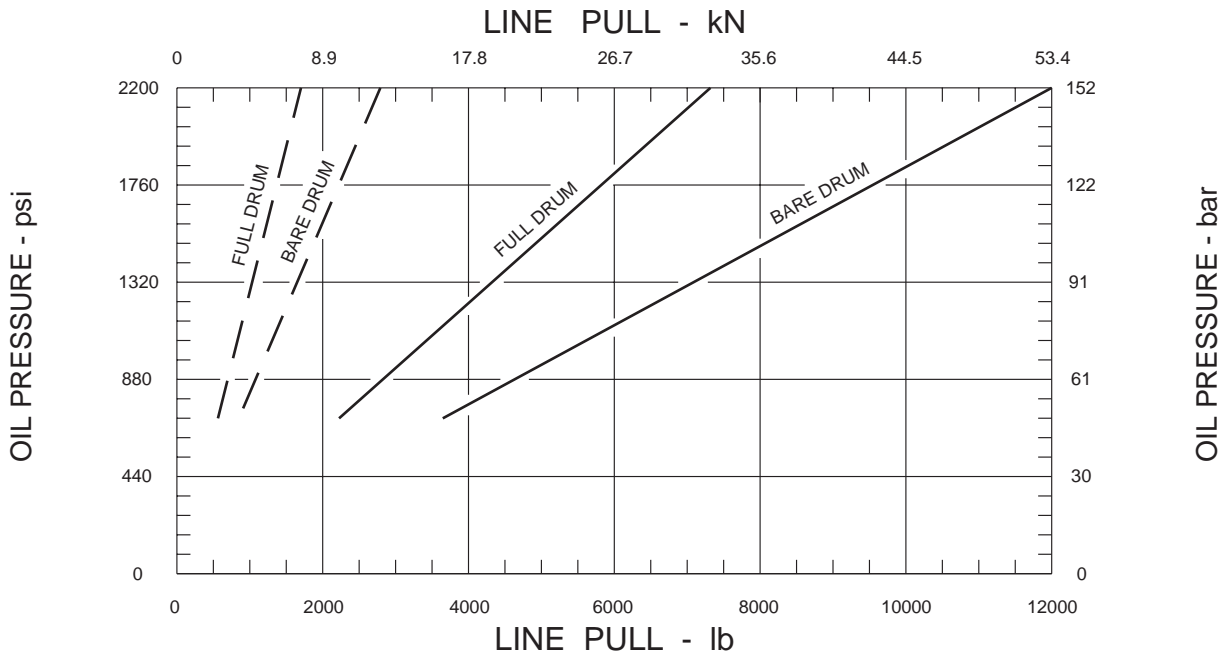

## LINE SPEED VS. OIL VOLUME

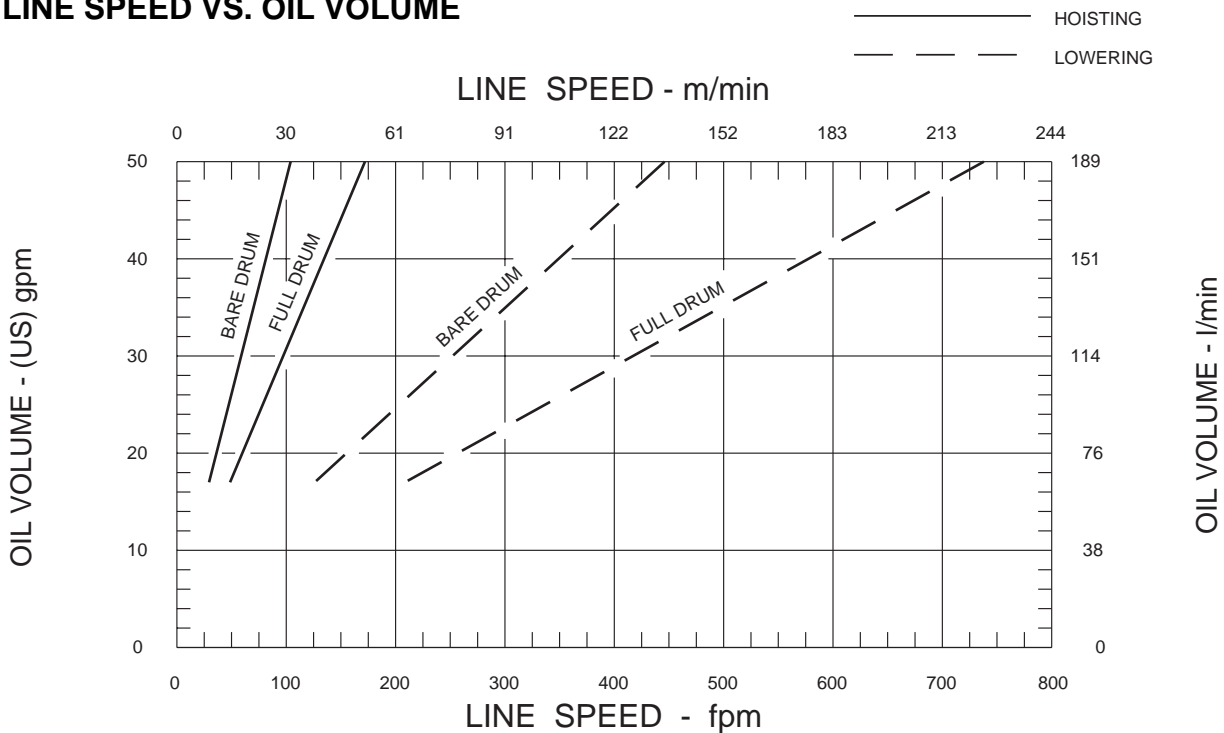

Performance graphs are based on standard hydraulic motor, gear ratio and cable drum with 5/8 inch diameter wire rope.

# TYPICAL HYDRAULIC CIRCUIT

HC-M12-E

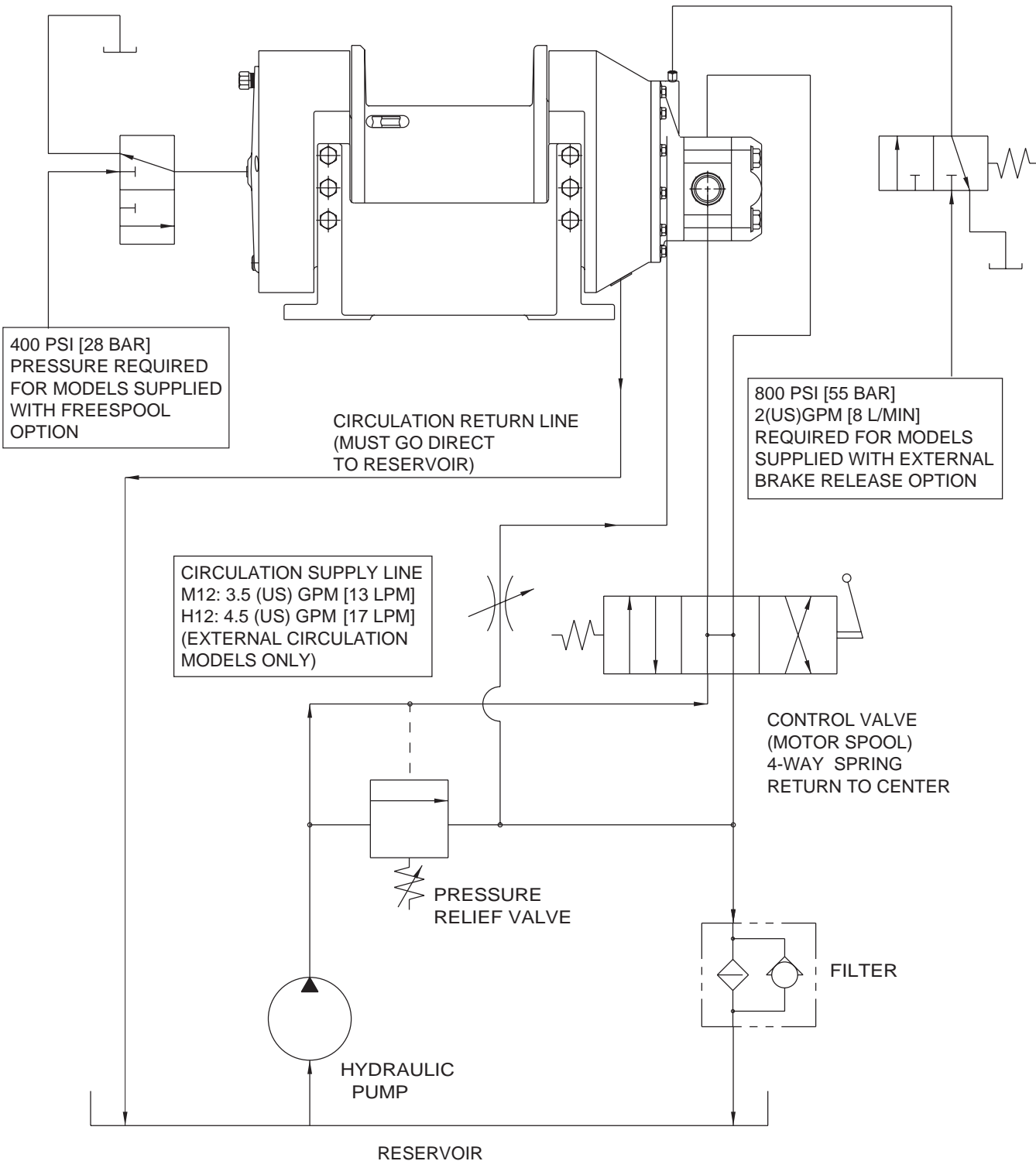

# RECOMMENDATIONS

## HYDRAULIC FLUID:

The hydraulic fluid selected for use with PULLMASTER planetary winches should be a high grade, petroleum based fluid, with rust, oxidation and wear resistance. Fluid cleanliness and operating viscosity are critical to winch reliability, efficiency and service life.

For optimum performance, the recommended viscosity range at operating temperature is 81 - 167 SUS (16 - 36 CS). For extreme operating conditions of short duration, the maximum viscosity range of 58 - 4635 SUS (10 - 1000 CS) should not be exceeded.

For optimum performance, the winch recommended hydraulic fluid temperature operating range is 80 - 150F (27 - 66 C). For extreme operating conditions of short duration, the maximum temperature range of -5 - 180F (-21 - 82 C) should not be exceeded.

## LUBRICATION:

The winch gear train requires oil bath lubrication. The winch is shipped from the factory without lubricating oil.

**IMPORTANT:** ADD LUBRICATING OIL BEFORE RUNNING WINCH.

Refer to INSTALLATION DIMENSIONS for location of lubricating oil fill port. Refer to APPENDIX A for quantity of oil required. For normal operating temperature use SAE 90 lubricating oil. Consult lubricating oil supplier or factory for temperatures beyond normal operating range.

## HYDRAULIC PUMP:

For maximum performance of the PULLMASTER planetary winch, the hydraulic pump must supply the maximum flow of hydraulic fluid at the hydraulic pressure stated in SPECIFICATIONS.

## HYDRAULIC CONTROL VALVE:

The standard control valve used for operation of the PULLMASTER planetary winch must have a four-way, spring return to neutral feature, which provides for open flow from the pressure ports of the winch to the reservoir in neutral position of the control (motor spool). It is important to point out that good speed control, especially when lowering a load, depends on the "metering" characteristics of the control valve. The better the oil flow is "metered" the better will be the speed control.

## HYDRAULIC PRESSURE RELIEF:

The hydraulic circuit for the PULLMASTER planetary winch requires a pressure relief set at the operating pressure (see SPECIFICATIONS). Usually, a pressure relief is part of the hydraulic control valve. Where this is not the case, a separate pressure relief valve must be installed and set at the recommended maximum pressure.

## HYDRAULIC RESERVOIR:

It is recommended that the hydraulic reservoir has sufficient capacity to provide good heat dissipation in order to prevent over-heating of the hydraulic fluid. The hydraulic reservoir should be made from clean and scale-free material to prevent contamination of the hydraulic fluid. In order to prevent air from being mixed with the hydraulic fluid, the reservoir should have an over-flow baffle separating the return lines from the suction line and all return lines should enter the reservoir below the fluid level. The reservoir should be mounted close to and above the hydraulic pump in a location which provides for free air circulation around the reservoir.

## HYDRAULIC HOSES:

The following hydraulic hoses are recommended for maximum efficiency of the PULLMASTER Model H12 planetary winch:

Pressure lines:	Equivalent to SAE 100R12-20
Circulation return line:	Equivalent to SAE 100R4-12
Circulation supply line*:	Equivalent to SAE 100R6-6

\*For external circulation models only.

It is recommended that a larger size of hydraulic hose is installed where the pressure lines or the circulation lines are excessively long.

## HYDRAULIC FILTER:

Hydraulic filter recommendations for the hydraulic circuit of the PULLMASTER planetary winch, based on a return line filter, are given as follows:

Average Atmosphere:	10 microns
Dusty Atmosphere:	5 microns

In order to prevent accidental stoppage of the return line flow, the oil filter should have a by-pass feature.

## USE OF AN E STOP:

### (FOR EUROPEAN MACHINERY DIRECTIVE APPLICATIONS)

The use of an E stop (emergency) is mandatory in the controls circuit. The E stop is to be placed in the operator's control panel. The E stop must be designed and placed in line with EN 60204 and EN 418.

# INSTALLATION INSTRUCTIONS



**DANGER**

**FAILURE TO FOLLOW INSTALLATION INSTRUCTIONS WILL  
RESULT IN PROPERTY DAMAGE, SEVERE INJURY OR DEATH.**

The initial installation or mounting of a PULLMASTER planetary winch is critically important for proper operation and performance. If the winch is mounted to an uneven surface, the centre line of the unit can be distorted to a point where the winch will not operate in either direction. It is therefore very important that the following instructions are observed when a PULLMASTER planetary winch is installed:

- 1) Make certain that the mounting platform is sufficiently strong in order to avoid deflection when a load is lifted.
- 2) Set the winch on the mounting platform and check for surface contact on all mounting pads of the winch.
- 3) If there is a space between the mounting surface and one of the mounting pads, the mounting surface is not even and the space below the mounting pad must be shimmed. If this condition exists, proceed as follows:
  - a) Install mounting bolts snug tight on the three mounting pads which are in contact with the mounting surface. (For mounting bolt size and grade see INSTALLATION DIMENSIONS.)
  - b) Measure the space underneath the fourth mounting pad with a feeler gauge and use shim stock of equivalent thickness in the space between the mounting pad and the mounting surface.
  - c) Only after this procedure should the fourth mounting bolt be installed. Tighten all four bolts per BOLT TORQUE CHART.
- 4) Fill the winch with lubricating oil. (See APPENDIX A for oil volume required.)
- 5) Use recommended circuit components and hydraulic hoses.
- 6) The circulation return line of the winch should be plumbed in such a manner that the brake housing remains full of oil at all times. Connect the return line directly to reservoir. Do not connect to a common return line.
- 7) Before operating the winch with a load, verify adequate circulation flow through the circulation return line as stated in TYPICAL HYDRAULIC CIRCUIT. Verify that pressure measured at the circulation supply port does not exceed the permissible pressure stated in SPECIFICATIONS. Winches equipped with the internal circulation option will supply circulation flow only when the winch is run in the lowering direction.
- 8) Verify that breather relief, item 130, is above oil level on end cover, item 120. Rotate end cover if breather relief is below oil level.

**IMPORTANT:** Do not replace breather relief with a pipe plug. The breather relief does not prevent oil seal failure but serves as an indicator or warning that the oil seals between brake housing and the cable drum interior have failed and must be replaced immediately. If these oil seals are changed, additional failure of the drum seal and potential damage to the end cover is prevented.

# OPERATING INSTRUCTIONS



**DANGER**

**FAILURE TO FOLLOW OPERATING INSTRUCTIONS WILL  
RESULT IN PROPERTY DAMAGE, SEVERE INJURY OR DEATH.**

After the PULLMASTER planetary winch has been installed in accordance with the INSTALLATION INSTRUCTIONS, the wire rope can be fastened to the cable drum.

**IMPORTANT:** The ropes, chains, slings, etc. are not part of the winch and are not covered by this manual. Refer to manufacturer's handling, inspection and maintenance recommendations to avoid potential accidents. For selection of ropes, etc. please check following product standards: DIN 15020, prEN818-1/9, prEN 1492-1/2, prEN 1677-1/3 and other relevant product standards.

- 1) The cable drum of the PULLMASTER planetary winch has two cable anchor slots, one for clockwise and one for counterclockwise hoisting. Standard rotation for hoisting is clockwise when looking at the hydraulic motor of the unit. It is critical to select the cable anchor slot which will permit winding of the wire rope on the drum in the correct direction of rotation. If the wire rope is wound on the cable drum in the wrong direction of rotation, the winch will have no braking capacity. Each winch is shipped from the factory with a label on the drum indicating the correct cable anchor slot.

## WIRE ROPE INSTALLATION

Clockwise hoisting winch shown.  
(Use cable anchor slot on opposite side of drum for counterclockwise hoisting winch.)

Feed the wire rope through the cable anchor slot. Loop rope back into slot as shown. Insert cable anchor into slot, small end first and long side nearest the drum flange. Pull rope tight to wedge rope in slot.

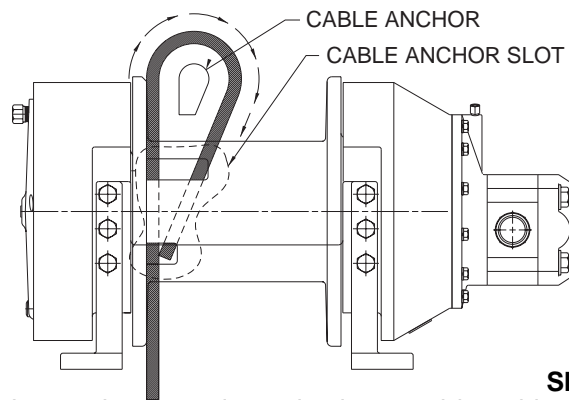

- 2) On wire rope installation, care must be taken that the wire rope is wrapped completely around the cable anchor and properly pulled into the cable anchor slot in the cable drum. The cable drum requires 3-4 wraps of wire rope for safety.
- 3) The winch operation is controlled by a single control valve lever which has a **forward**, a **reverse** and a **neutral** position. Speed control in either direction is obtained by modulation of the control valve lever. Maximum line speed in either direction is obtained when the control valve lever is moved as far as it can go. The disc brake of the winch will come on automatically when the winch control lever is returned to **neutral**.
- 4) Always warm up equipment prior to operating winch, particularly in low ambient temperature. Circulate hydraulic oil through the winch control valve for several minutes to warm the hydraulic system. To prime the winch with warm oil, operate the winch at slow speed, forward and reverse, several times.
- 5) Prevent corrosion damage to winch interior. If not used regularly, run winch up and down at least once every two weeks.
- 6) To ensure proper winch installation and function, raise and lower a full test load to a safe height before using winch for regular operation at the start of each shift.

If, after a new installation, the winch does not function properly, refer to the TROUBLESHOOTING section of this manual.

# TROUBLE SHOOTING

**GENERAL:**

In most cases, when the hydraulic winch does not perform satisfactorily, the cause of malfunction is found somewhere in the hydraulic circuit. Before the winch is removed from its mounting and disassembled, all of the hydraulic circuit components should be checked for proper function.

**IMPORTANT:**

**The hydraulic oil volume relates to the line speed or rpm of the winch.**

Therefore, if the winch does not produce the specified maximum rated line speed or drum rpm, a loss of hydraulic flow somewhere in the hydraulic circuit system can be analysed. If this condition exists, install a flow meter into the hydraulic circuit to check the volume supplied to the pressure port of the hydraulic winch motor when the winch control is completely opened. The flow meter should indicate the maximum operating volume. If this test indicates a loss of hydraulic flow, check the hydraulic pump, the relief valve and the control valve. If the pump is driven by V-belts, check for belt slippage.

**The hydraulic pressure relates to the line pull or lifting capacity of the winch.**

If the winch will not lift the specified maximum line pull, install a pressure gauge into the pressure line leading to the hoisting port on the hydraulic winch motor. Stall the winch to prevent rotation of the drum and then open the control valve. Check the hydraulic pressure reading of the installed pressure gauge. If the pressure reads below the specified maximum operating pressure, look for trouble in the hydraulic pump, the relief valve and the control valve. If the pump is driven by V-belts, check for belt slippage. When checking oil pressure and volume in the hydraulic circuit, make certain that the hydraulic reservoir is filled to the top level.

Only if the hydraulic system has been checked and found to be in order, use the following indications for probable causes of failure in the winch:

FAILURE	PROBABLE CAUSE
<p><b>Winch will not produce line pull at maximum pressure as listed in SPECIFICATIONS.</b></p>	<ul style="list-style-type: none"> <li>a) Winch is mounted to an uneven surface. (See INSTALLATION INSTRUCTIONS.)</li> <li>b) Cable sheaves or block purchase operated with the winch are not turning freely.</li> <li>c) Damage or wear in the hydraulic motor.</li> <li>d) Relief valve may be set too low.</li> <li>e) Excessive back pressure in the hydraulic circuit might cause the automatic brake to release momentarily.</li> </ul>
<p><b>Winch will not produce line speed at maximum volume as listed in SPECIFICATIONS.</b></p>	<ul style="list-style-type: none"> <li>a) Winch is mounted to an uneven surface. (See INSTALLATION INSTRUCTIONS.)</li> <li>b) Cable sheaves or block purchase operated with the winch are not turning freely.</li> <li>c) Damage or wear in the hydraulic motor</li> <li>d) Excessive back pressure in the hydraulic circuit.</li> </ul>
<p><b>Winch will not reverse.</b></p>	<ul style="list-style-type: none"> <li>a) Leakage out of the brake piston prevents the brake from being released against the brake springs. This is caused by damaged O-ring seals on the brake piston.</li> <li>b) The O-ring seals, on the brake release channel between the motor adaptor and the brake housing is damaged. If this failure occurs there will be substantial leakage between the motor adaptor and brake housing.</li> <li>c) Insufficient hydraulic pressure. (See SPECIFICATIONS for minimum operating pressure.)</li> <li>d) Winch is mounted to an uneven surface. (See INSTALLATION INSTRUCTIONS.)</li> </ul>

# TROUBLE SHOOTING CONTINUED

FAILURE	PROBABLE CAUSE
<b>Brake will not hold.</b>	<ul style="list-style-type: none"> <li>a) Brake plates or divider plates have been damaged by contamination in the hydraulic fluid, or lack of circulation flow in the brake housing.</li> <li>b) Brake piston is seized in the brake housing because of contamination in the hydraulic fluid.</li> <li>c) Excessive back pressure in the return line causes the brake to be released.</li> <li>d) Control valve has incorrect spool, which traps hydraulic pressure in the brake piston when the control valve handle is returned to neutral position. For proper function of the automatic brake, both pressure ports of the winch must be open to the reservoir in neutral position of the control valve.</li> <li>e) Wire rope is fastened to the incorrect cable anchor slot.</li> <li>f) Sprag clutch is damaged or surfaces where sprag clutch engages on motor drive shaft or connecting shaft are worn or indented.</li> <li>g) Winch supplied with external brake release option is not plumbed per HYDRAULIC CIRCUIT. Failure to vent external brake release port to reservoir may trap pressure and cause winch brake to slip.</li> </ul>
<b>Brake vibrates when lowering a load.</b>	<ul style="list-style-type: none"> <li>a) Pump is too slow. Pump rpm must be maintained at normal operating speed when a load is lowered.</li> <li>b) Brake is running too hot. This can be caused by a complete lack of, or insufficient circulation flow. To check the circulation, observe the flow of oil from the circulation return line of the winch (approx. 4.5 (US) gpm - 17 l/min) when the winch is reversed.</li> <li>c) Control valve has poor metering characteristics.</li> <li>d) Damaged brake plates or divider plates.</li> <li>e) The over-running clutch, which connects the motor shaft with the brake assembly, is damaged.</li> <li>f) Air mixed with hydraulic oil (foamy oil).</li> </ul>
<b>Oil leaks.</b>	<ul style="list-style-type: none"> <li>a) Oil leaks from the hydraulic motor flange and the motor adaptor are caused by damaged O-ring seals.</li> <li>b) Oil leaks occurring between the cable drum flanges and housings are caused by excessive pressure in the brake housing. Excessive pressure will damage the oil seal which separates the brake housing from the cable drum interior.</li> <li>c) If the breather relief on the end cover leaks, the seal between the drum interior and the brake housing is damaged and must be replaced. This condition is caused by excessive pressure in the brake housing of the winch, operation with the incorrect hydraulic fluid during cold weather, or a restriction in the circulation return line leading back to tank.</li> </ul>

Refer to the SERVICE INSTRUCTIONS if it becomes necessary to disassemble the Model H12 winch.

# SERVICE INSTRUCTIONS

## GENERAL:

Before attempting disassembly of the PULLMASTER Model H12 planetary winch the following instructions for disassembly and reassembly should be read and understood.

It is suggested that all expendable parts, such as O-rings and oil seals are not reused on reassembly. It is therefore important to have a seal kit (Part No. 23123), and providing the hydraulic motor has to be serviced, a seal kit (Part No. 23121) on hand before the unit is taken apart. Two new needle bearings, item 875, may also be required (Part No. 25723).

**NOTE:** Backup washers may be included with seal kit. Install with oil seals as per instructions. If not present in seal kit, the oil seals supplied do not require backup washers.

A clean working area is of prime importance, similar to conditions used for service work on any other hydraulic component.

All parts, as they are removed from the winch assembly, should be inspected for wear and damage. Worn or damaged parts must be replaced. Thoroughly clean parts before reassembly. Do not use solvent to clean the brake friction plates.

During reassembly, lubricate all O-rings and oil seals with grease before installation.

In the following service instructions, reference to parts is made by numbers and shown on the applicable group drawings.

## DISASSEMBLY

For the majority of required service or repair work, disassembly is required only on the brake housing of the PULLMASTER Model H12 planetary winch. There are no special tools needed for the service or repair work and no adjustments or calibrations are necessary. Proceed with the disassembly as follows:

### DISASSEMBLY OF HYDRAULIC MOTOR ASSEMBLY:

If the analysed service or repair work requires access to the interior of the brake housing, the hydraulic motor should not be disassembled. In this case, the hydraulic motor should be removed together with the motor adaptor as a complete assembly. If a problem has been analysed to be in the hydraulic motor, proceed with the disassembly as follows:

1) Remove four hex capscrews, item 951, together with lockwashers, item 953, from motor assembly.

**IMPORTANT:** Failure to exercise care when removing the motor port end cover or gear housing could permanently damage the machined surfaces of these motor components. Take care not to damage machined surfaces of motor components at disassembly.

2) Remove (pry loose if necessary) port end cover, item 870, together with bearings, item 875, and ring seal, item 877. Thrust plate, item 885, and dowel pins, item 865, may stay in the gear housing.

3) If the thrust plate comes off with end cover, carefully pry it off of bearings, item 875, and discard pocket seals, item 887, if present.

4) Remove gear set, item 881, which consists of two gears which are a matched set.

5) Carefully pry gear housing, item 861, off of motor adaptor, item 800. Thrust plate, item 885, and dowel pins, item 865, may stay in gear housing.

6) If thrust plate has stayed on motor adaptor, carefully pry it off of bearings, item 875, and discard pocket seals, item 887, if present.

7) Discard body seals, item 869. It is also advisable to replace ring seals, item 877, at this time. Bearings, item 875, must be removed to allow access to ring seals.

# SERVICE INSTRUCTIONS CONTINUED

Pocket seals, body seals, and ring seals in the hydraulic motor assembly are not part of the winch seal kit. The seal kit for the hydraulic motor can be ordered from the factory under Part No. 23121.

## REMOVAL OF HYDRAULIC MOTOR ASSEMBLY:

If disassembly of the hydraulic motor is not necessary proceed as follows:

- 1) Remove 12 hex capscrews, item 821, with lockwashers, item 823, from motor adaptor, item 800. Since brake springs, item 752, apply pressure against inside of motor adaptor, it is recommended that hex capscrews are unscrewed one turn at a time until spring pressure has been released. Complete motor assembly, including motor adaptor, can now be removed from brake housing assembly.
- 2) Remove and discard O-ring, item 801, and O-ring, item 707. (O-ring, item 801, seals pressure transfer hole for automatic brake release and is situated on flange of motor adaptor.)

## DISASSEMBLY OF BRAKE HOUSING ASSEMBLY:

- 1) After motor assembly has been removed, all parts of brake assembly are accessible. Remove 16 brake springs, item 752. Thoroughly examine springs for damage and measure overall length. Overall spring length should be 1.99 inch. If any spring measures less than 1.93 inch, replace all springs as a set.
- 2) Pull motor drive shaft, item 730, out of brake housing, together with sprag clutch aligner, item 724, support washer, item 717, two sprag clutches, item 723, and circlip, item 727.
- 3) Remove circlip, item 727, from motor drive shaft to take off two sprag clutches, item 723, support washer, item 717, and sprag clutch aligner, item 724.



**DANGER**

**MINOR SURFACE DEFECTS WHERE THE SPRAG CLUTCH ENGAGES THE MOTOR DRIVE SHAFT AND CONNECTING SHAFT, WILL RESULT IN BRAKE FAILURE AND ALLOW THE LOAD TO DROP, CAUSING PROPERTY DAMAGE, SEVERE INJURY OR DEATH. THOROUGHLY INSPECT THESE AREAS AND, IF NECESSARY, REPLACE MOTOR DRIVE SHAFT, SPRAG CLUTCH AND CONNECTING SHAFT AS A SET.**

- 4) Thoroughly inspect surface of motor drive shaft where sprag clutch engages. If any indentation or surface damage is detected, replace motor drive shaft, sprag clutch and connecting shaft as a set.
- 5) Pull connecting shaft, item 600, out of centre bore of brake housing, together with brake hub, item 720. Thoroughly inspect bore of connecting shaft where sprag clutch engages. If any indentation or surface damage is detected, replace connecting shaft, sprag clutch and motor drive shaft as a set.
- 6) Remove thrust bearing, item 617, with its two thrust washers, item 615.
- 7) To separate brake hub, item 720, from connecting shaft, item 600, remove circlip, item 721.
- 8) Remove circlip, item 621.
- 9) Push bearing sleeve, item 620, out of bore of connecting shaft. Discard O-ring, item 625, and oil seal, item 623. Check needle bearing, item 627, for wear or damage and replace if necessary.
- 10) Pull brake piston, item 750, out of brake housing using two 1/2-13NC bolts screwed into two puller holes in piston and discard O-rings, item 751 and item 753.

# SERVICE INSTRUCTIONS CONTINUED

- 11) Thoroughly examine inner bores of brake housing and outer diameters of brake piston for scoring caused by hydraulic fluid contamination. Minor surface damage may be repaired by polishing with a fine emery cloth.



**DANGER**

**DAMAGED FRICTION OR DIVIDER PLATES WILL REDUCE BRAKING CAPACITY AND ALLOW THE LOAD TO DROP, CAUSING PROPERTY DAMAGE, SEVERE INJURY OR DEATH. SOLVENT MAY DAMAGE THE FRICTION PLATES. DO NOT USE SOLVENT TO CLEAN THE FRICTION PLATES. PERFORM THOROUGH INSPECTION AND, IF NECESSARY, REPLACE FRICTION AND DIVIDER PLATES AS A SET.**

- 12) Remove 12 friction plates, item 715, together with 13 divider plates, item 714, and inspect for damage or wear. Plates should be flat and smooth. Plates should not show heat discoloration. Paper material on friction plates should be intact and grooved. If any damage is detected, replace friction and divider plates as a set.
- 13) Remove brake spacer, item 712.
- 14) Remove oil seal, item 711, backup washer, item 710, and discard.

All parts have now been removed from brake housing. If further disassembly is required, proceed as follows:

- 15) Remove breather relief, item 130, pipe plug, item 121, and tip winch to drain lubricating oil out of drum and final housing.
- 16) Stand winch up on end and remove 12 capscrews, item 551, and lockwashers, item 553, to remove base, item 550.
- 17) Brake housing, item 700, can now be lifted out of cable drum, item 500.
- 18) Remove primary sungear, item 440.

## **DISASSEMBLY OF FINAL DRIVE:**

Stand winch on cable drum flange with final end up and disassemble as follows:

- 1) Remove internal retaining ring, item 124, and pull end cover, item 120, out of final drive housing, item 100.
- 2) Discard O-ring, item 123, and inspect planet hub stopper, item 126, and sungear stopper, item 122, for excessive wear. Replace planet hub stopper if less than .30 inch and sungear stopper if less than .21 inch thick.
- 3) Remove final planet hub assembly from final housing, item 100.
- 4) Inspect three final planet gears, item 320, for damage or wear. If it is necessary to remove final planet gears, remove circlip, item 313, and press planet pin, item 310, out of planet hub, item 300. Inspect loose rollers, item 323, and two thrust washers, item 321, and replace if damaged.
- 5) Using a hydraulic press, carefully press down on final sungear, item 340. This will cause primary gear, item 430, to push ball bearings, items 507 and 509, and oil seal, item 515, out of cable drum, item 500.
- 6) Discard oil seal, item 515.

## **DISASSEMBLY OF PRIMARY DRIVE:**

- 1) Primary internal gear, item 430, can now be taken out of cable drum with primary planet assembly and primary sungear, item 440.
- 2) Inspect three internal gear stoppers, item 412, for excessive wear and replace if necessary.

# SERVICE INSTRUCTIONS CONTINUED

- 3) If primary planet assembly has to be taken apart, remove circlips, item 411, and push primary planet pins, item 410, out of planet hub, item 400.
- 4) Remove primary planet gears, item 420, together with needle bearings, item 423, and thrust washers, item 421. Inspect needle bearings and thrust washers for wear and damage and replace if necessary.
- 5) Check sungear stopper, item 444, on centre bore of planet hub for excessive wear and replace if less than .21 inch thick.
- 6) To separate final drive housing, item 100, from cable drum, item 500, put remaining assembly in a horizontal position. Remove circlip, item 513, then insert two heel bars between flange of cable drum and final drive housing and gently pry cable drum out of ball bearing, item 103.
- 7) Remove circlip, item 109, to take ball bearing out of final drive housing. Remove and discard oil seal, item 105.

## REASSEMBLY

Thoroughly clean all parts. Use only new, well-greased O-rings and oil seals. Unless otherwise specified, torque fasteners per BOLT TORQUE CHART as back of manual.

### REASSEMBLY OF FINAL DRIVE:

Reassemble final drive end of winch as follows:

- 1) Press new, well-greased oil seal, item 105, into final housing, item 100.
- 2) Press ball bearing, item 103, into final housing and secure with circlip, item 109.
- 3) Press cable drum, item 500, into ball bearing, item 103, and secure with circlip, item 513.
- 4) Reassemble final planet hub assembly. Press needle bearing, item 323, into final planet gear, item 320. Position thrust washers, item 321, on either side of planet gear and press planet pin, item 310, into final planet hub, item 300. Retain with circlip, item 313.
- 5) Insert final planet hub assembly into final housing, item 100. Ensure that planet hub spline is fully engaged with cable drum, item 500.
- 6) Install new, well-greased O-ring, item 123, into end cover, item 120. Verify that planet hub stopper, item 126, and sungear stopper, item 122, are installed into end cover.
- 7) Gently insert end cover into final housing, item 100, and fasten with retaining ring, item 124.

### REASSEMBLY OF PRIMARY DRIVE:

Turn winch over, resting on end cover with cable drum opening facing up. Reassemble primary drive as follows:

- 1) Verify circlip, item 343, is installed on splined end of final sungear, item 340. Insert final sungear into cable drum and engage gear end with three final planet gears.
- 2) Reassemble primary planet hub assembly. Press sungear stopper, item 444, into primary planet hub, item 400. Press needle bearing, item 423, into primary planet gear, item 420. Position thrust washers, item 421, on either side of planet gear and press planet pin, item 410, into primary planet hub, item 400. Retain with circlip, item 411.
- 3) Install primary planet hub onto end of final sungear, item 340, inside of cable drum, item 500.
- 4) Install internal gear, item 430, over top of three primary planet gears, item 420. Ensure gear teeth are fully engaged by rotating cable drum.
- 5) Press ball bearings, items 507 and 509, into cable drum.
- 6) Press new, well-greased oil seal, item 515, into cable drum.

# SERVICE INSTRUCTIONS CONTINUED

- 7) Install primary sun gear, item 440, into centre of three primary planet gears, item 420. Ensure gear teeth are fully engaged by rotating cable drum.
- 8) Carefully insert brake housing, item 700, into ball bearings, items 507 and 509.
- 9) Fasten base, item 550, onto housings using 12 capscrews, item 551, and lockwashers, item 553.

## REASSEMBLY OF BRAKE ASSEMBLY:

- 1) Install new backup washer, item 710, and new oil seal, item 711, in centre bore of brake housing, item 700.
- 2) Install bearing sleeve, item 620, with needle bearing, item 627, new O-ring, item 625, backup washer, item 622, and new oil seal, item 623, in bore of connecting shaft.
- 3) Install circlip, item 621.
- 4) Carefully insert connecting shaft, item 600, into centre bore of brake housing until its splined end engages with spline of primary internal gear, item 430.
- 5) Install thrust bearing, item 617, and thrust washers, item 615, onto brake hub, item 720.
- 6) Slide brake hub, item 720, onto spline of connecting shaft, item 600, ensuring that thrust washer, item 615, does not fall off. Secure with circlip, item 721.



**DANGER**

**INCORRECT ASSEMBLY OF THE FRICTION PLATE AND DIVIDER PLATE STACK WILL REDUCE BRAKING CAPACITY AND ALLOW THE LOAD TO DROP, CAUSING PROPERTY DAMAGE, SEVERE INJURY OR DEATH. REASSEMBLE PER INSTRUCTIONS.**

- 7) Install brake spacer, item 712, into brake housing. Starting and finishing with a divider plate, alternately install 13 divider plates, item 714, and 12 friction plates, item 715.
- 8) Liberally grease O-ring, item 751, and O-ring, item 753, and install on brake piston, item 750.
- 9) Slide brake piston into brake housing with holes for brake springs facing out of brake housing assembly.
- 10) Install two sprag clutches, item 723, sprag clutch aligner, item 724, and support washer, item 717, on motor drive shaft, item 730. Secure this assembly in position with circlip, item 727.

**IMPORTANT:** For proper brake function, verify that sprag clutch is installed correctly. When viewed from motor end, motor drive shaft of clockwise hoisting winch must turn freely clockwise and lock in counterclockwise direction.

- 11) Carefully slide motor drive shaft, item 730, into connecting shaft, item 600, until it engages spline of primary sun gear, item 440.
- 12) Install 16 brake springs, item 752, in brake piston.
- 13) Liberally grease new O-ring, item 801, and install on transfer hole for brake release pressure on flange of motor adaptor, item 800. Install new, well-greased O-ring, item 707, on flange of motor adaptor.
- 14) Slide hydraulic motor assembly onto splined end of motor drive shaft, item 730, and line up pressure transfer holes of brake housing and motor adaptor. Fasten motor assembly to brake housing using 12 hex capscrews, item 821, with lockwashers, item 823. Screws should be tightened evenly, one turn at a time.

# SERVICE INSTRUCTIONS CONTINUED

## REASSEMBLY OF HYDRAULIC MOTOR:

If the hydraulic motor was disassembled, the following procedure should be followed for reassembly:

**NOTE:** Thrust plates with six slots require pocket seals as indicated below. Thrust plates without slots do not require these seals.

- 1) Clean all parts thoroughly before reassembly and apply grease liberally to all seals. Use only new seals (seal kit Part No. 23121) for hydraulic motor.
- 2) Install six new pocket seals, item 887, on each thrust plate, item 885. Seal kit includes a single strip of rubber. Using a sharp knife, cut lengths to fit openings in thrust plates. Press one thrust plate, together with six pocket seals, onto bearings, item 875, installed in motor adaptor, item 800, so that pocket seals are against motor adaptor.
- 3) Install well-greased body seal, item 869, on each side of gear housing, item 861. Slide gear housing together with body seals, onto motor adaptor, lined up on two dowel pins. Tap on tight using soft headed hammer.
- 4) Install gear set, item 881, in gear housing. (Longer gear with internal spline goes into top position.)
- 5) Press other thrust plate, complete with six new pocket seals, onto bearings installed in port end cover so pocket seals are facing port end cover.
- 6) Install port end cover, item 870, together with two bearings, item 875, and new ring seal, item 877, onto gear housing, lined up on two dowel pins, item 865. Tap on tight using soft head hammer. Install and lightly torque four hex capscrews, item 951, and lockwashers, item 953, to approximately 50 ft-lb (70 Nm).
- 7) Plumb winch assembly to hydraulic supply and torque motor capscrews according to the following procedure:
  - Ensure that circulation supply flow is being supplied to brake housing.
  - Run winch, with no load, in hoisting direction at reduced speed (approximately 30% of maximum volume).
  - With winch running, evenly tighten four capscrews, item 951, to 200 ft-lb (270 Nm).
  - Test motor operation by running winch at full speed in both directions.

**IMPORTANT:** Before operating winch, add lubricating oil up to level of end cover oil fill port. (Refer to INSTALLATION INSTRUCTIONS for location of fill port. Refer to APPENDIX A for oil volume required.)

To ensure proper reassembly, run winch in both direction without load.



**DANGER**

**LIFTING A LOAD WITH A NEWLY SERVICED WINCH WILL ENABLE AN INSTALLATION OR SERVICE PROBLEM TO GO UNDETECTED AND ALLOW THE LOAD TO DROP CAUSING PROPERTY DAMAGE, SEVERE INJURY OR DEATH. TO ENSURE PROPER REINSTALLATION, REFER TO PROCEDURES AND TESTS DESCRIBED IN "INSTALLATION" AND "OPERATING INSTRUCTIONS".**

# RECOMMENDED MAINTENANCE

Winch gear train lubricating oil should be changed after the initial six months or 50 hours of operation, whichever comes first. Lubricating oil should then be changed every 12 months or 500 operating hours, whichever comes first.

Hydraulic system fluid should be changed at least once every 12 months.

For optimum performance over an extended period of time, the following preventative maintenance service should be done every 12 months or 500 hours, whichever comes first:

- 1) Disconnect all hydraulic hoses and remove the winch from its mounting.
- 2) Disassemble the winch as per instructions.
- 3) Discard and replace all O-rings and oil seals.
- 4) Inspect all parts for wear and replace if necessary.
- 5) Clean all parts and inspect for wear and damage as per instructions. Replace worn or damaged parts as required.
- 6) Follow INSTALLATION and OPERATING INSTRUCTIONS when returning winch to its mounting.

When ordering parts for the PULLMASTER Model H12 planetary winch, always quote the complete model and serial number of the unit.

**MODEL NO.** \_\_\_\_\_

**SERIAL NO.** \_\_\_\_\_

PULLMASTER WINCH CORPORATION reserves the right to change specifications and the design of PULLMASTER planetary winches at any time without prior notice and without incurring any obligations.

# PARTS REFERENCE - FINAL DRIVE

ITEM NO.	QTY.	PART NO.	DESCRIPTION
100	1	20283	FINAL HOUSING
103	1	25095	BALL BEARING # 6020
105	1	25142	OIL SEAL
109	1	25093	CIRCLIP ROTOR CLIP HO-600
120	1	21813	END COVER
121	2	25032	PIPE PLUG 1/2 - 14 NPT
122	1	19036	SUNGEAR STOPPER
123	1	25088	O-RING -279 13" ID 1/8" CS
124	1	20161	RETAINING RING
126	1	21180	PLANET HUB STOPPER
130	1	20458	BREATHER RELIEF ASSEMBLY
300	1	20152	PLANET HUB
310	3	20162	PLANET PIN
311	3	25411	CIRCLIP ROTOR CLIP SH-100
313	3	25122	CIRCLIP ROTOR CLIP C-100
320	3	20158	PLANET GEAR
321	6	25098	THRUST WASHER TORRINGTON # TRA 1625
323	3	25097	NEEDLE BEARING TORRINGTON # BH1620
340	1	*	SUNGEAR
343	1	25240	CIRCLIP ROTOR CLIP SH-137
500	1	*	CABLE DRUM
502	1	20171	CABLE ANCHOR
503	1	25085	PIPE PLUG 3/8 - 18 NPT
513	1	25092	CIRCLIP ROTOR CLIP SH-393
550	1	*	BASE
551	12	25139	CAPSCREW - HEXHEAD 5/8 - 11NC X 1.50 GRADE 5
553	12	25099	LOCKWASHER 5/8" HI-COLLAR
			* These parts vary according to drum code. Refer to APPENDIX B.

Refer to PAGE 22 for winch seal kit and PAGE 28 for ASSEMBLY DRAWING.

# FINAL DRIVE GROUP

G1031-A

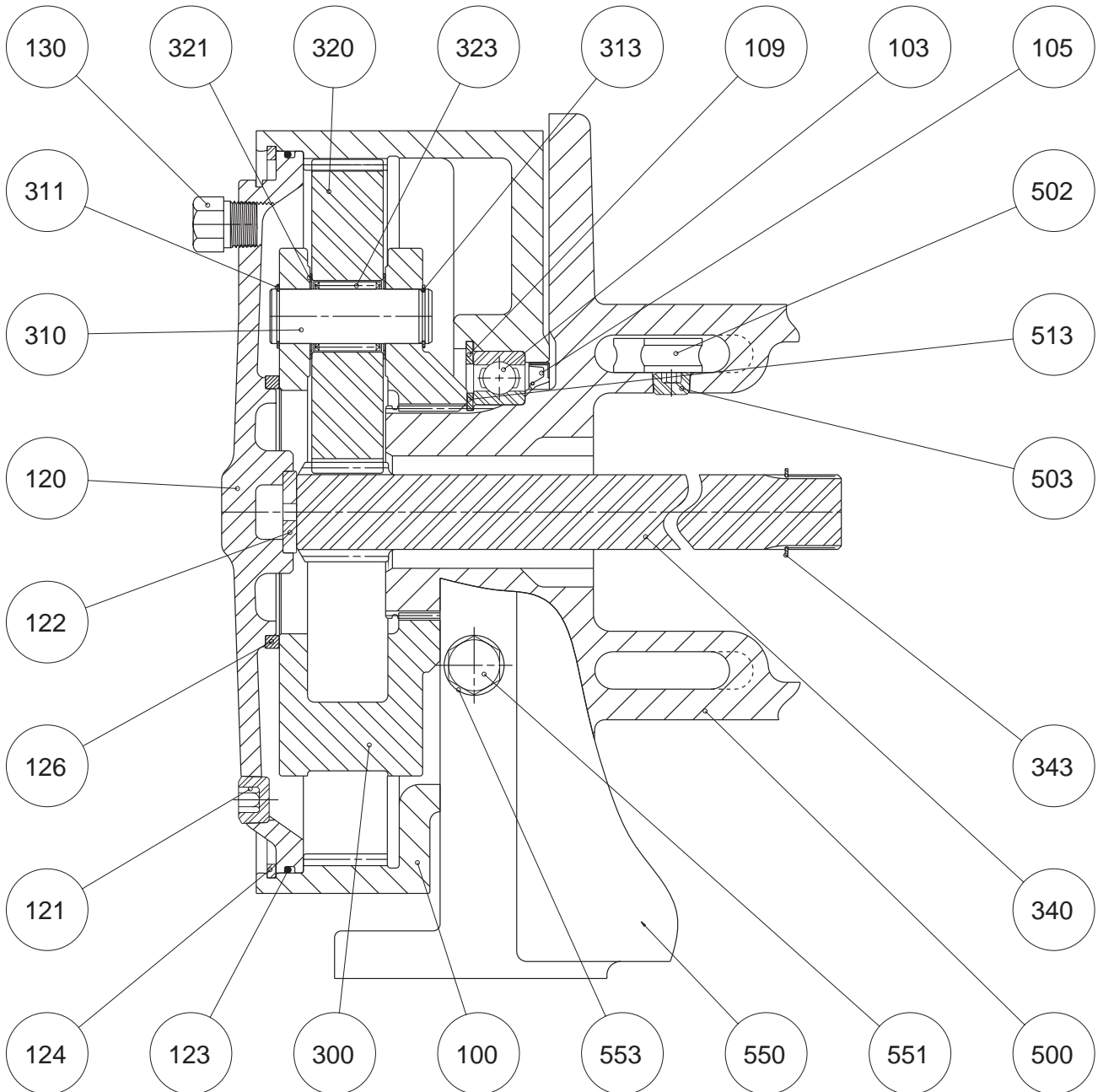

Groups drawings may reference more parts than are actually present in a specific assembly. Parts that are referenced on the drawing but are not on the PARTS REFERENCE list should be ignored.

# PARTS REFERENCE - BRAKE GROUP

ITEM NO.	QTY.	PART NO.	DESCRIPTION
400	1	20095	PLANET HUB
410	3	21169	PLANET PIN
411	3	25060	CIRCLIP ROTOR CLIP C-62
412	3	21176	INTERNAL GEAR STOPPER
413	3	25119	CIRCLIP ROTOR CLIP SH-62
420	3	20101	PLANET GEAR
421	6	25064	THRUST WASHER TORRINGTON # TRA 1018
423	3	25269	NEEDLE BEARING TORRINGTON # BH1016
430	1	21174	INTERNAL GEAR
440	1	20178	SUNGEAR
444	1	19036	SUNGEAR STOPPER
507	1	25095	BALL BEARING #6020
509	1	25150	BALL BEARING #6022
515	1	25151	OIL SEAL
600	1	21175	CONNECTING SHAFT
602	1	20035	RETAINING RING
605	2	25200	NEEDLE BEARING TORRINGTON #B4216
615	2	25178	THRUST WASHER TORRINGTON #TRD 5266
617	1	25177	THRUST BEARING TORRINGTON # NTA 5266
620	1	21177	BEARING SLEEVE
621	1	25709	CIRCLIP ROTOR CLIP HO-175
623	1	26025	OIL SEAL
625	1	25196	O-RING -030 1 5/8" ID 1/16" CS
627	1	25232	NEEDLE BEARING TORRINGTON # B2012
700	1	21303	BRAKE HOUSING
703	1	25331	PLASTIC CAPLUG 3/4 NPT THREADED
707	1	25192	O-RING -174 8-3/4" ID 3/32" CS
710	1	21179	BACKUP WASHER FOR OIL SEAL #25195
711	1	25195	OIL SEAL
712	1	21377	BRAKE SPACER
714	13	21252	DIVIDER PLATE
715	12	25194	FRICTION PLATE
717	1	25729	SUPPORT WASHER ANDERTON # R.28/40/2.0
720	1	21362	BRAKE HUB
721	1	25055	CIRCLIP ROTOR CLIP SH-262
723	2	25187	SPRAG CLUTCH
724	1	21193	SPRAG CLUTCH ALIGNER
727	1	25492	CIRCLIP ROTOR CLIP SH-106
730	1	21178	MOTOR DRIVE SHAFT
731	1	25500	CIRCLIP ROTOR CLIP C-93
750	1	20262	PISTON
751	1	25190	O-RING -90 DURO -171 8" ID 3/32" CS
752	16	20028	BRAKE SPRING
753	1	25191	O-RING -90 DURO -267 8-1/4" ID 1/8" CS
		23123	WINCH SEAL KIT, CONSISTS OF ITEMS: 105, 123, 515, 623, 625, 707, 710, 711, 751, 753 AND 801

Refer to PAGE 28 for ASSEMBLY DRAWING.

# BRAKE GROUP

G1032-A

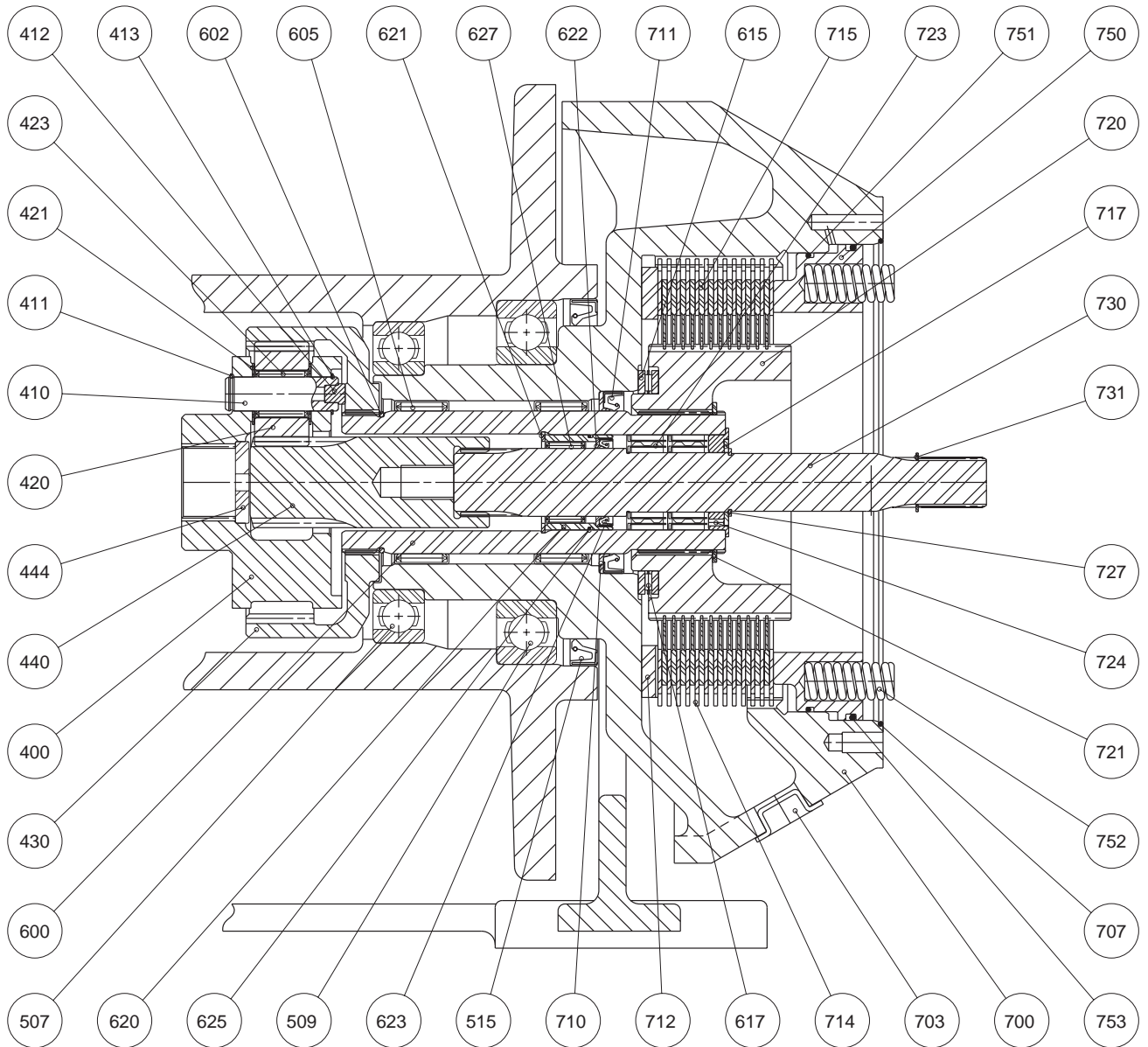

Group drawings may reference more parts than are actually present in a specific assembly. Parts that are referenced on the drawing but are not on the PARTS REFERENCE list should be ignored.

# PARTS REFERENCE - MOTOR GROUP

ITEM NO.	QTY.	PART NO.	DESCRIPTION
800	1	21390	MOTOR ADAPTOR
801	1	25310	O-RING -90 DURO -012 3/8" ID 1/16" CS
802	1	*	*
803	1	25370	PIPE PLUG 1/16 - 27 NPT
804	1	*	*
805	2	25040	PIPE PLUG 1/8 - 27 NPT
807	1	*	*
809	1	*	*
821	12	25118	CAPSCREW - HEX HEAD 3/8 - 16 NC X 1.25 GRADE 5
823	12	25037	LOCKWASHER 3/8"
861	1	25724	GEAR HOUSING
865	4	25326	DOWEL PIN
869	2	25612	SEAL - BODY
870	1	21758	PORT END COVER
875	4	25723	NEEDLE BEARING
877	2	25722	SEAL - RING
881	1	25728	GEAR SET
885	2	25725	THRUST PLATE
887	1	25321	SEAL STRIP
899	2	25031	PIPE PLUG 1/4 - 18 NPT
929	1	*	*
950	1	*	SUB - ASSY MOTOR -097
951	4	25324	CAPSCREW - HEX HEAD
953	4	25325	WASHER
955	2	25557	PLASTIC CAPPLUG 1.625 -12 THREADED
		23121	MOTOR SEAL KIT, CONSISTS OF ITEMS: 869, 877 AND 887
			<b>NOTE:</b> ITEM 950 MOTOR SUB-ASSY, CONSISTS OF ITEMS: 800, 802, 803, 804, 805, 807, 809, 861, 865, 869, 870, 875, 877, 881, 885, 887, 899, 929, 951, 953 AND 955
			* These part numbers and descriptions vary according to brake code. Refer to APPENDIX C.

Refer to PAGE 22 for winch seal kit and PAGE 28 for ASSEMBLY DRAWING.

# MOTOR GROUP

G1033-A

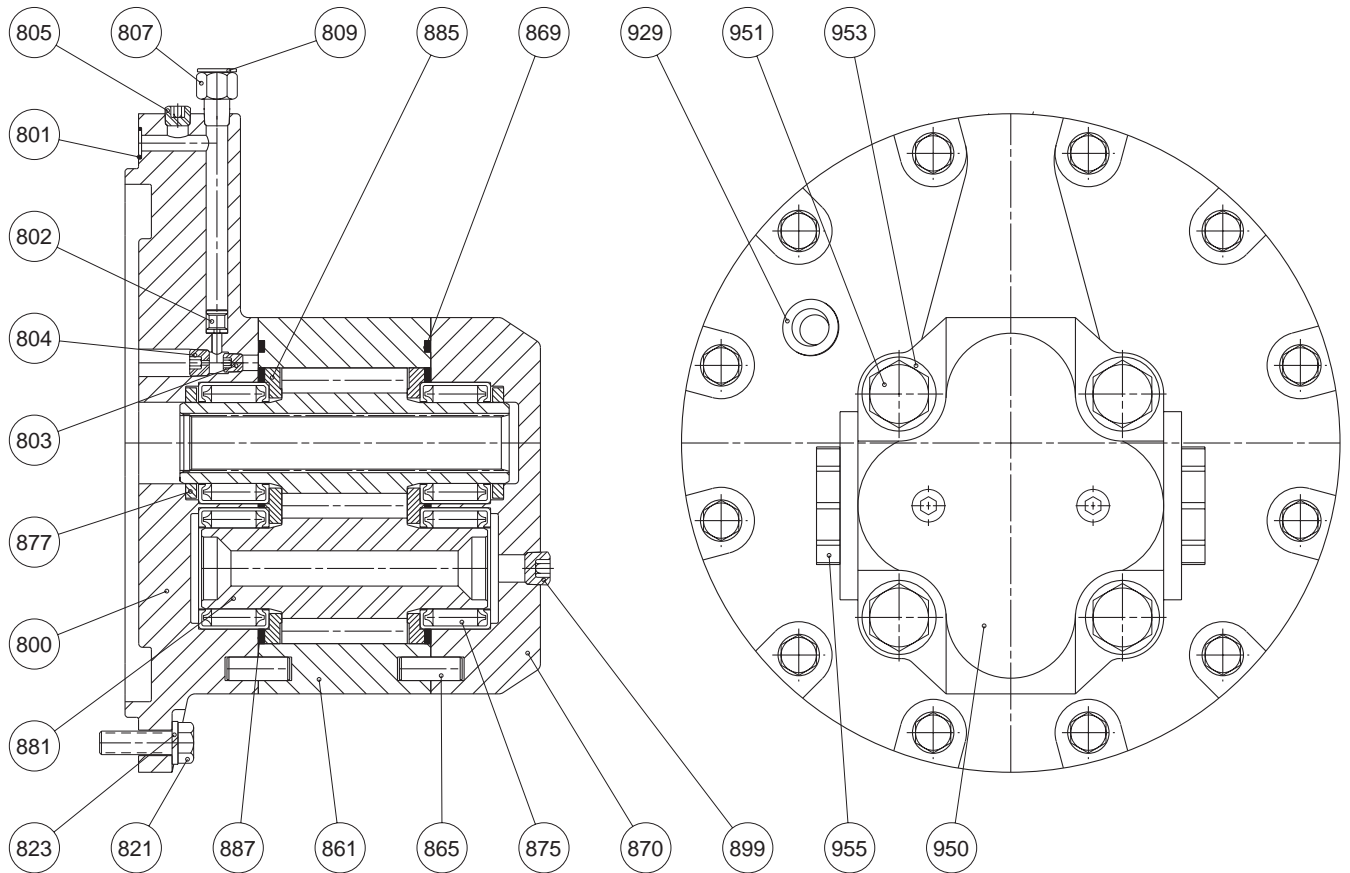

Group drawings may reference more parts than are actually present in a specific assembly. Parts that are referenced on the drawing but are not on the PARTS REFERENCE list should be ignored.



# INSTALLATION DIMENSIONS

I1017-2-D & I1017-3-D

## Dimensions in inches (Dimensions in millimeters)

DRUM CODE	A	B	C	D	E	F	G	H	J	K	M	R	S
-1	7.6 (194)	14.6 (371)	10.0 (254)	6.8 (173)	15.9 (404)	15.6 (396)	19.1 (486)	17.000 (431.80)	23.8 (604)	10.6 (269)	8.56 (217)	11.000 (279.40)	17.5 (445)
-2	9.6 (244)	14.6 (371)	10.0 (254)	6.8 (173)	15.9 (404)	15.6 (396)	19.1 (486)	17.000 (431.80)	23.8 (604)	10.6 (269)	8.56 (217)	11.000 (279.40)	17.5 (445)
-3	9.6 (244)	16.6 (422)	13.0 (330)	6.8 (173)	16.9 (429)	15.6 (396)	22.1 (562)	20.000 (508.00)	26.8 (681)	10.6 (269)	8.56 (217)	11.000 (279.40)	17.5 (445)
-5	7.6 (194)	16.6 (422)	10.0 (254)	6.8 (173)	16.9 (429)	15.6 (396)	19.1 (486)	17.000 (431.80)	23.8 (604)	10.6 (269)	8.56 (217)	11.000 (279.40)	17.5 (445)
-6	9.6 (244)	16.6 (422)	10.0 (254)	6.8 (173)	16.9 (429)	15.6 (396)	19.1 (486)	17.000 (431.80)	23.8 (604)	10.6 (269)	8.56 (217)	11.000 (279.40)	17.5 (445)
-7	7.6 (194)	16.6 (422)	13.0 (330)	6.8 (173)	16.9 (429)	15.6 (396)	22.1 (562)	20.000 (508.00)	26.8 (681)	10.6 (269)	8.56 (217)	11.000 (279.40)	17.5 (445)
-11	7.6 (194)	25.0 (635)	12.5 (318)	6.9 (175)	26.0 (660)	20.5 (521)	22.1 (562)	20.000 (508.00)	26.8 (681)	15.5 (394)	13.50 (343)	11.000 (279.40)	22.5 (572)

## Dimensions in inches (Dimensions in millimeters)

HYDRAULIC MOTORS				
COMMERCIAL WM51 GEAR MOTORS				
MOTOR CODE	GEAR WIDTH	MOTOR PORT SIZE SAE O-RING	I	L
-95	2.50 (63.5)	15/8 - 12	6.9 (175)	6.0 (152)
-96	2.25 (57.2)		6.6 (168)	6.0 (152)
-97	2.00 (50.8)		6.4 (163)	6.0 (152)
-98	1.50 (38.1)	15/16 - 12	5.9 (150)	6.0 (152)
-99	1.00 (25.4)	11/16 - 12	5.4 (137)	6.0 (152)
-114	1.75 (44.5)	15/16 - 12	6.2 (157)	6.0 (152)
SAE CODE 61 3000 PSI FLANGE				
-139	2.00 (50.8)	1 1/4	6.4 (163)	6.0 (152)
-140	1.75 (44.5)	1	6.2 (157)	6.0 (152)
-141	1.00 (25.4)	3/4	5.4 (137)	6.0 (152)

# ASSEMBLY DRAWING

G1031-A & G1032-A & G1033-A

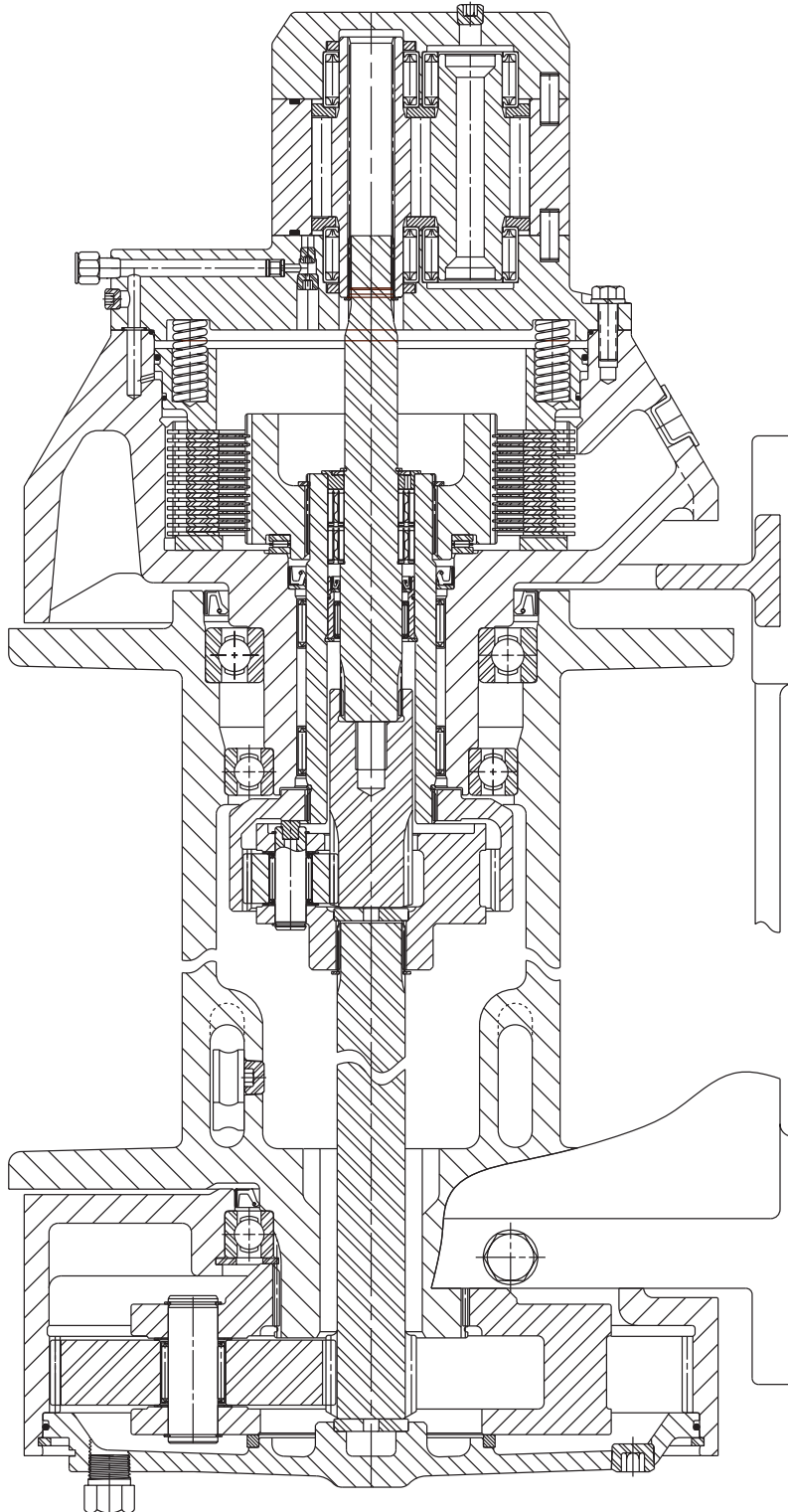

# APPENDIX A

DRUM CODE	CABLE DRUM SIZES INCHES (MILLIMETERS)			WIRE ROPE STORAGE FEET (METERS)			LINE PULL AT MAXIMUM PRESSURE - HOISTING* POUNDS (KILOWEIGHTS)		HOISTING LINE SPEED AT MAXIMUM VOLUME* FEET/MINUTE (METERS/MINUTE)		MAXIMUM ALLOWABLE LINE PULL - LOWERING* POUNDS (KILOWEIGHTS)		LOWERING LINE SPEED AT MAXIMUM VOLUME* FEET/MINUTE (METERS/MINUTE)		LUBRICATING OIL VOLUME REQUIRED  U.S. GALLONS (LITERS)
	BARREL	FLANGE	LENGTH	5/8 in	9/16 in	1/2 in	BARE DRUM	FULL DRUM	BARE DRUM	FULL DRUM	BARE DRUM	FULL DRUM	BARE DRUM	FULL DRUM	
-1	7.6 (194)	14.6 (371)	10.0 (254)	222 (68)	287 (87)	364 (111)	12121 (53.9)	7143 (31.8)	104 (32)	176 (54)	2769 (12.3)	1689 (7.5)	449 (137)	762 (232)	1.0 (3.8)
-2	9.6 (244)	14.6 (371)	10.0 (254)	162 (49)	226 (69)	245 (75)	9756 (43.4)	7143 (31.8)	129 (39)	176 (54)	2252 (10.0)	1710 (7.6)	558 (170)	762 (232)	1.5 (5.7)
-3	9.6 (244)	16.6 (422)	13.0 (330)	341 (104)	440 (134)	559 (170)	9756 (43.4)	6250 (27.8)	129 (39)	201 (61)	2252 (10.0)	1474 (6.6)	558 (170)	871 (266)	1.8 (6.8)
-5	7.6 (194)	16.6 (422)	10.0 (254)	323 (98)	399 (122)	489 (149)	12121 (53.9)	6250 (27.8)	104 (32)	201 (61)	2796 (12.3)	1458 (6.5)	449 (137)	871 (266)	1.0 (3.8)
-6	9.6 (244)	16.6 (422)	10.0 (254)	262 (80)	339 (103)	430 (131)	9756 (43.4)	6250 (27.8)	129 (39)	201 (61)	2252 (10.0)	1474 (6.6)	558 (170)	871 (266)	1.5 (5.7)
-7	7.6 (194)	16.6 (422)	13.0 (330)	419 (128)	519 (158)	636 (194)	12121 (53.9)	6250 (27.8)	104 (32)	201 (61)	2796 (12.3)	1458 (6.5)	449 (137)	871 (266)	1.2 (4.5)
-11	7.6 (194)	25.0 (635)	12.5 (318)	985 (300)	1237 (377)	1527 (465)	12121 (53.9)	4103 (18.2)	104 (32)	306 (93)	2796 (12.3)	986 (4.4)	449 (137)	1327 (405)	1.2 (4.5)

\* Performance specifications are based on standard hydraulic motor with 5/8 inch diameter rope.

# APPENDIX B

DRUM CODE	ITEM		
	340	500	550
	FINAL SUNGEAR	CABLE DRUM	BASE
- 1	20198	20201	20148
- 2	20198	20186	20148
- 3	20305	20299	20293
- 5	20198	20300	20148
- 6	20198	20302	20148
- 7	20305	20309	20293
- 11	20305	21122	21132

# APPENDIX C

## BRAKE CODE

ITEM NO.	PART DESCRIPTION	- 3	- 4	- 5	- 6	- 7	- 8	- 9	- 10
		PART NUMBERS							
802	SHUTTLE	N/A	20849	20849	N/A	N/A	20849	20849	N/A
804	ORIFICE PLUG	21483	21483	21483	21483	N/A	N/A	N/A	N/A
804	1/8-27 NPT PIPE PLUG	N/A	N/A	N/A	N/A	25040	25040	25040	25040
807	1/8-27 NPT PIPE PLUG	25040	N/A	N/A	25040	25040	N/A	N/A	25040
807	1/8-27 NPT PIPE ADAPTOR	N/A	25622	25622	N/A	N/A	25622	25622	N/A
809	1/8 NPT CAPPLUG	N/A	25374	25374	N/A	N/A	25374	25374	N/A
929	3/8 NPT CAPPLUG	N/A	N/A	N/A	N/A	25393	25393	25393	25393
929	3/8-18 NPT PIPE PLUG	25085	25085	25085	25085	N/A	N/A	N/A	N/A
950	MOTOR SUB-ASSY	21938	22014	22015	22016	22017	22018	22019	22020

# BOLT TORQUE CHART

BOLT DIAMETER Inches	TORQUE lb-ft	TORQUE Nm
1/4	9	12
5/16	18	24
3/8	32	43
7/16	50	68
1/2	75	102
9/16	110	149
5/8	150	203
3/4	265	359
7/8	420	569
1	640	868
1 1/8	800	1085
1 1/4	1000	1356
1 3/8	1200	1627
1 1/2	1500	2034

**NOTE:** Unless otherwise specified, torque bolts per above chart.